

AI AND DATA STRATEGY: DRIVING EACH OTHER FORWARD

JAN MESKENS

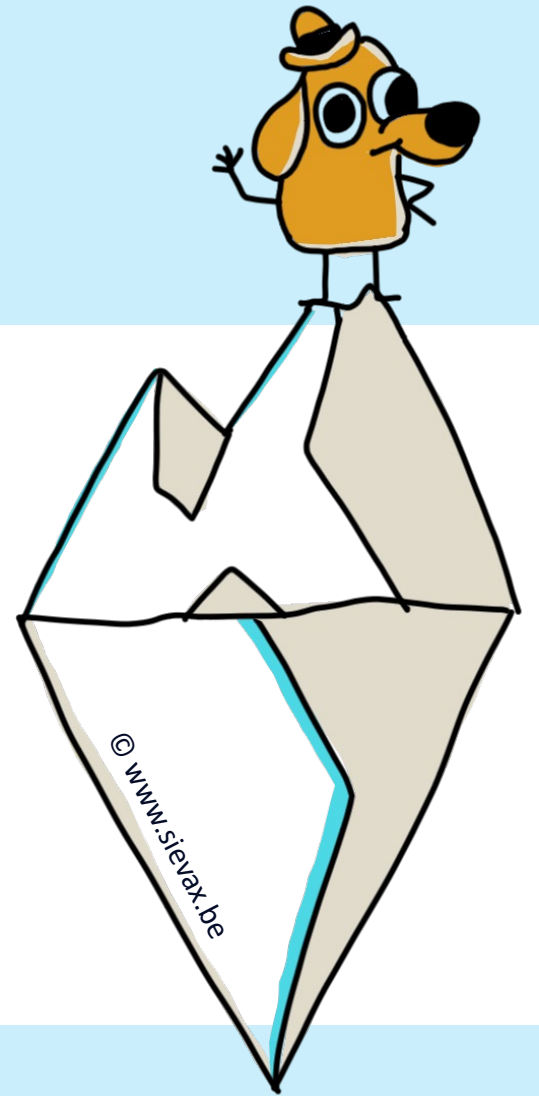



Jan Meskens

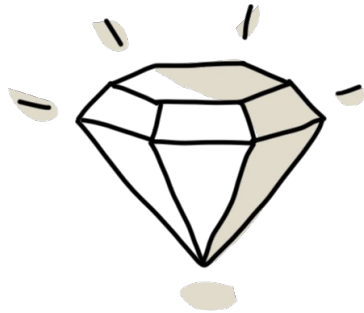

Data and AI Strategy
Consultant

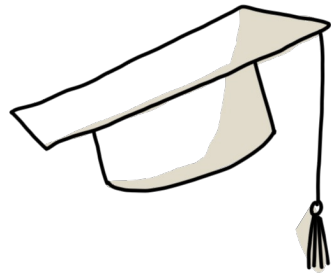

Lecturer of several AI and
Data Strategy Trainings



Founder and Manager
of Sievax

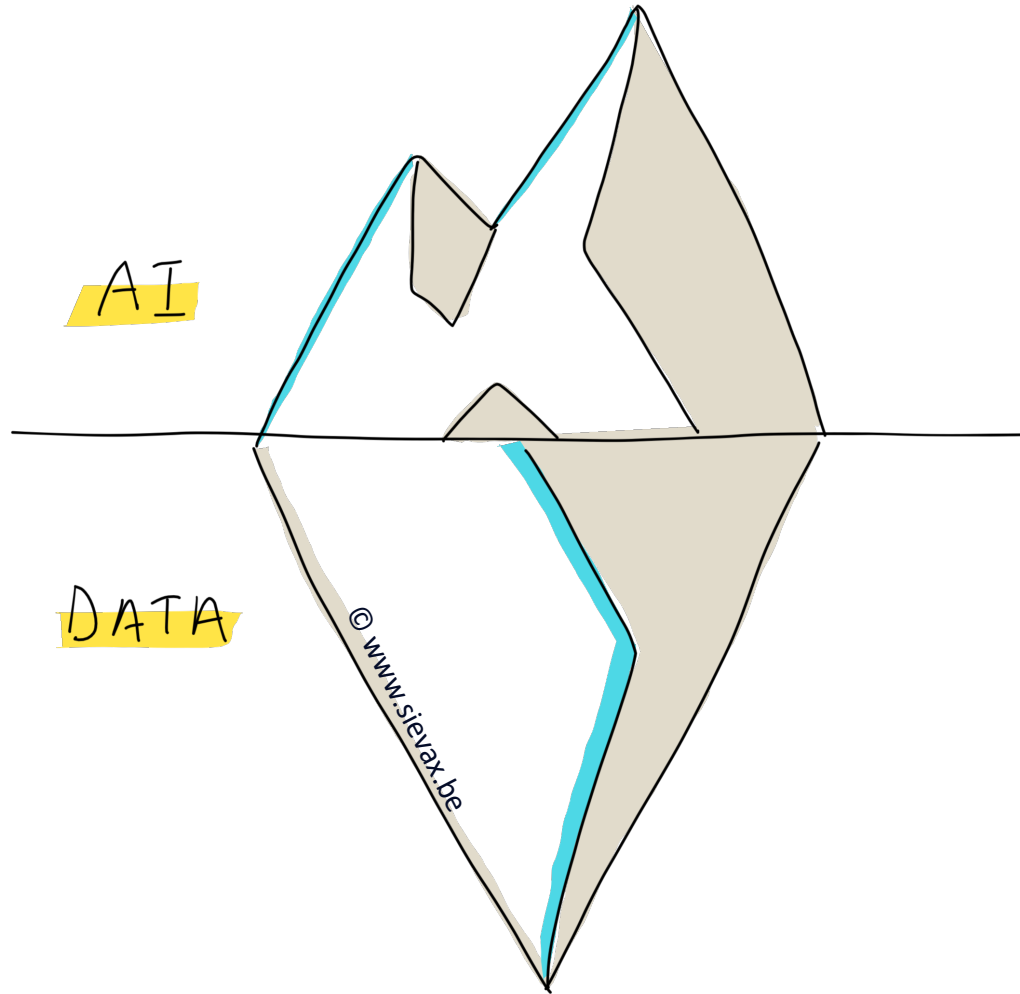

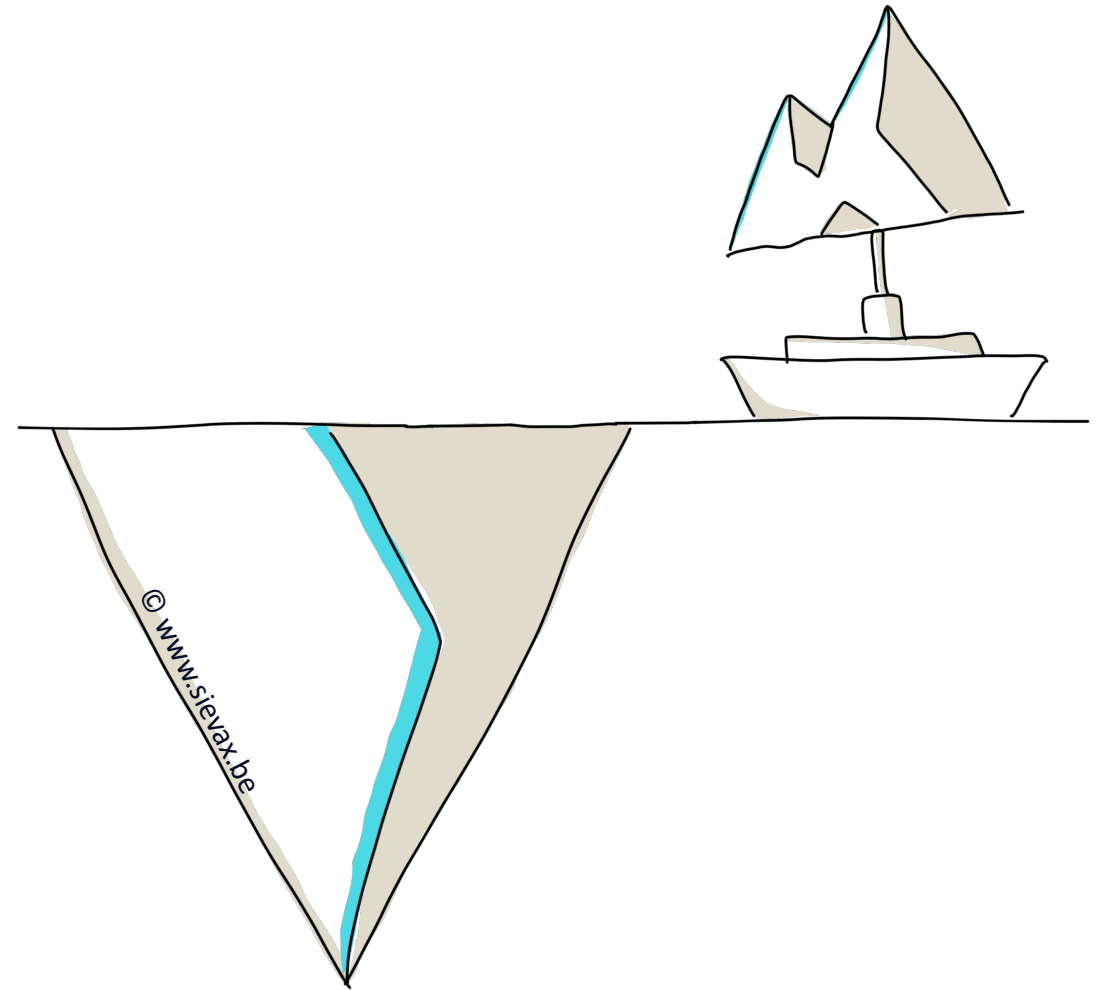
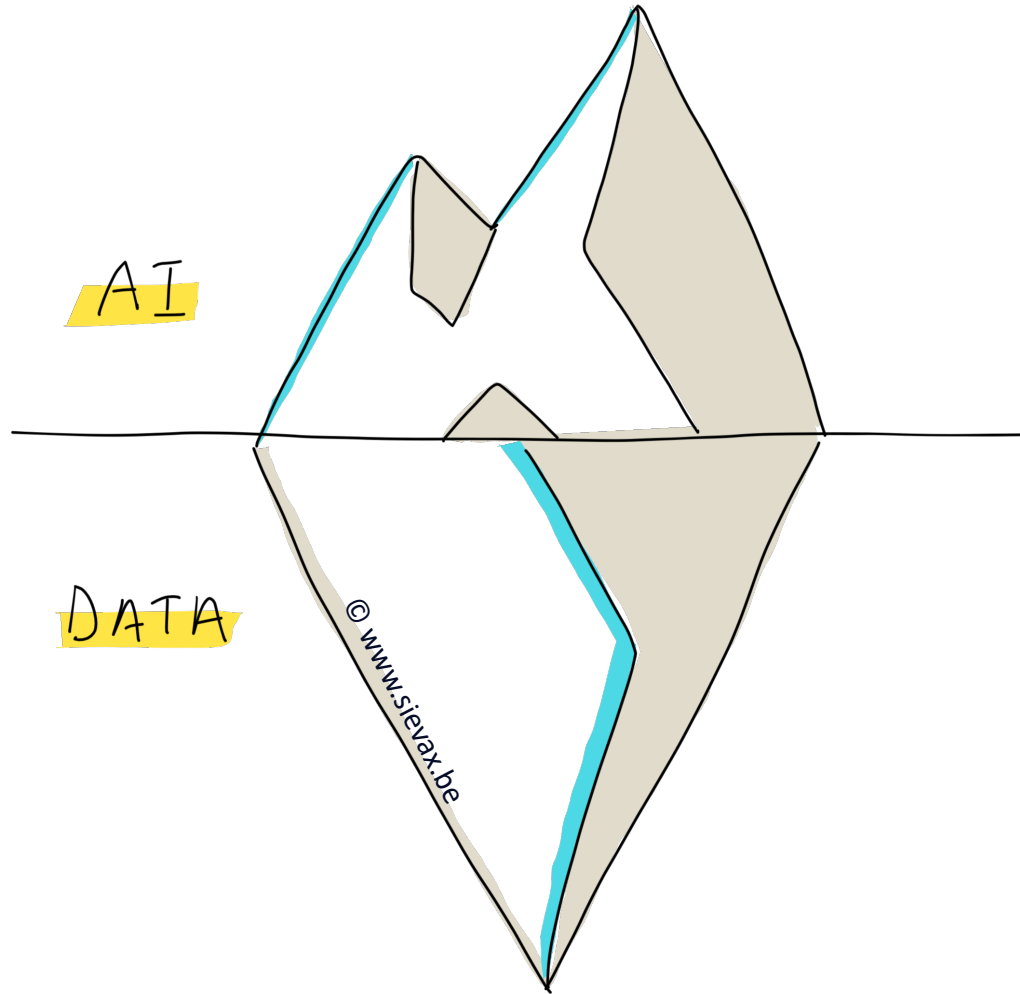

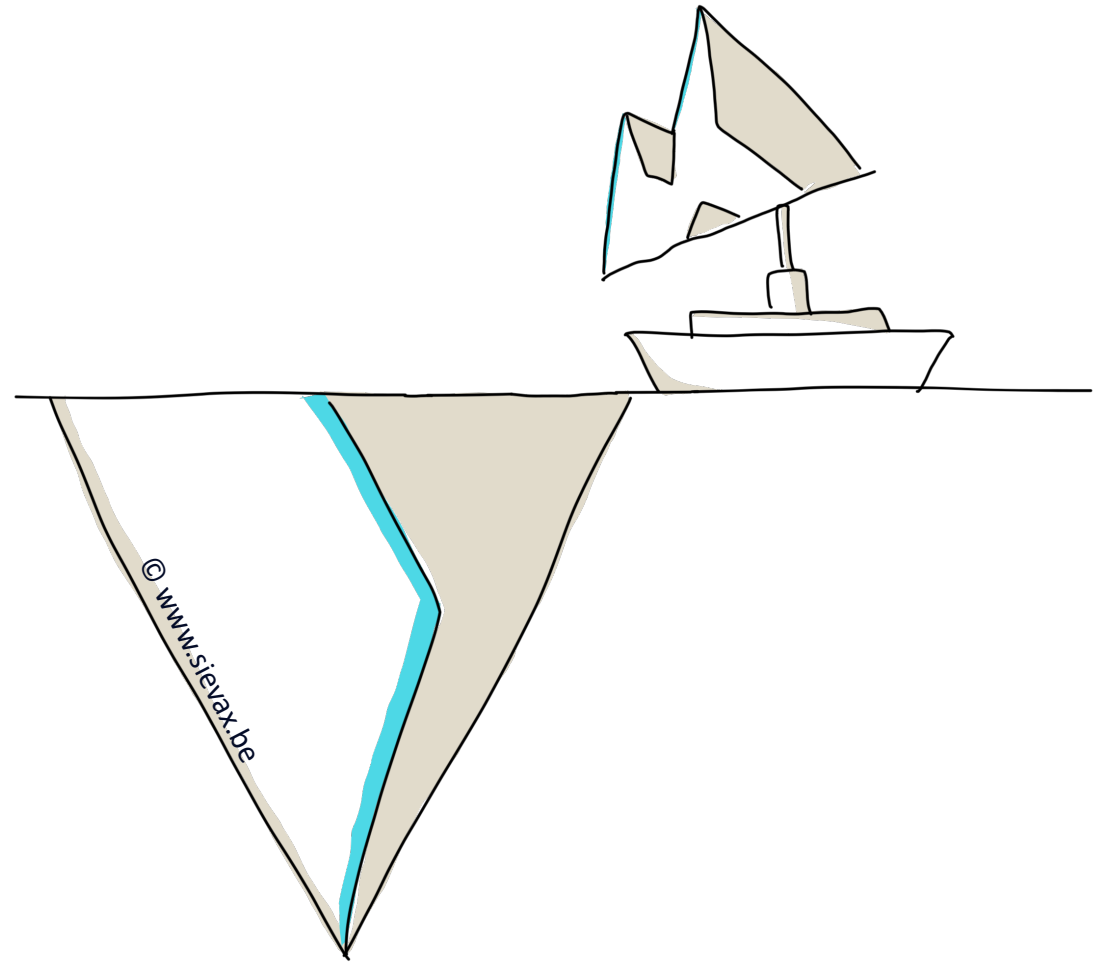
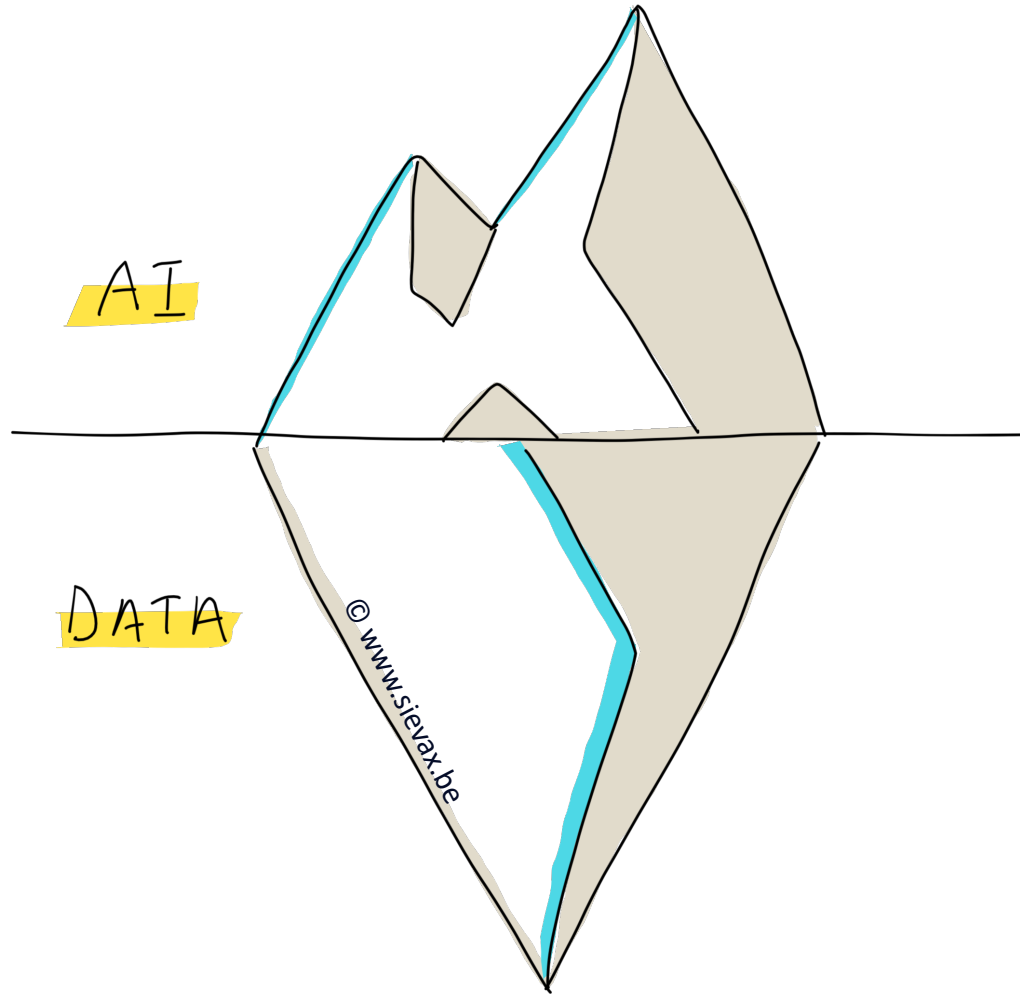

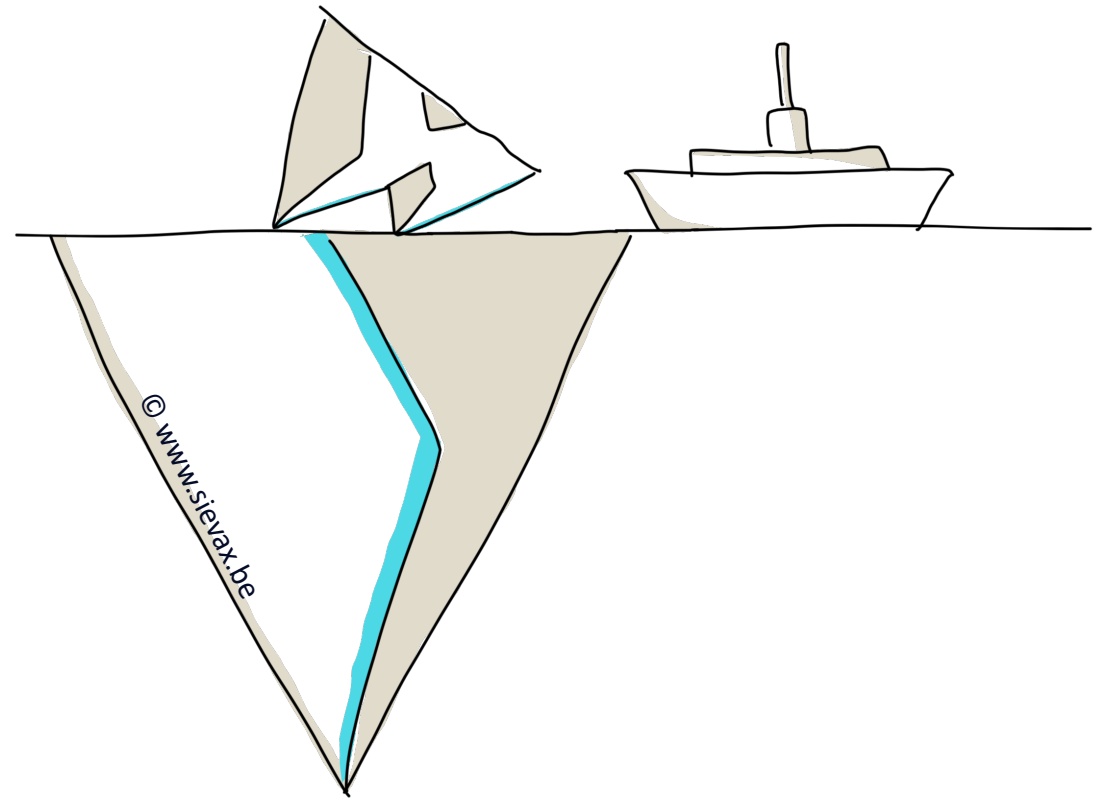
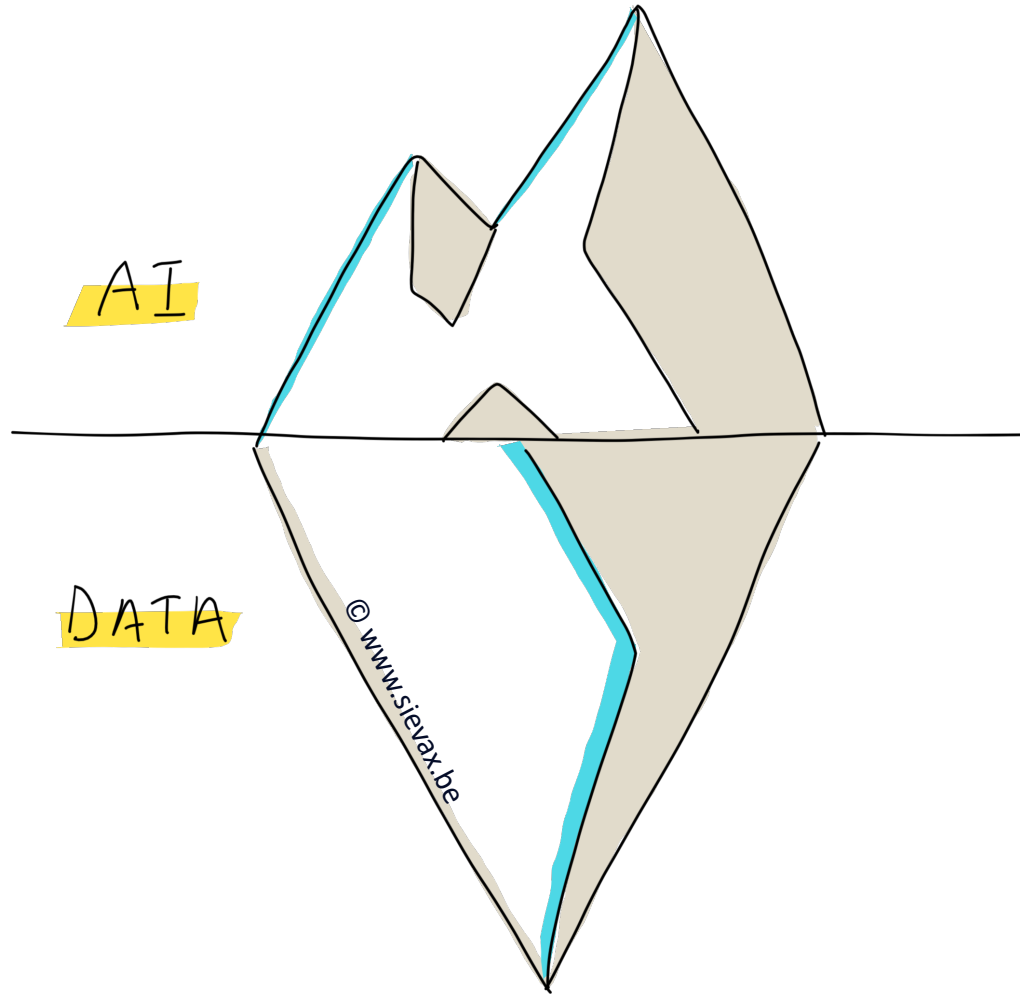

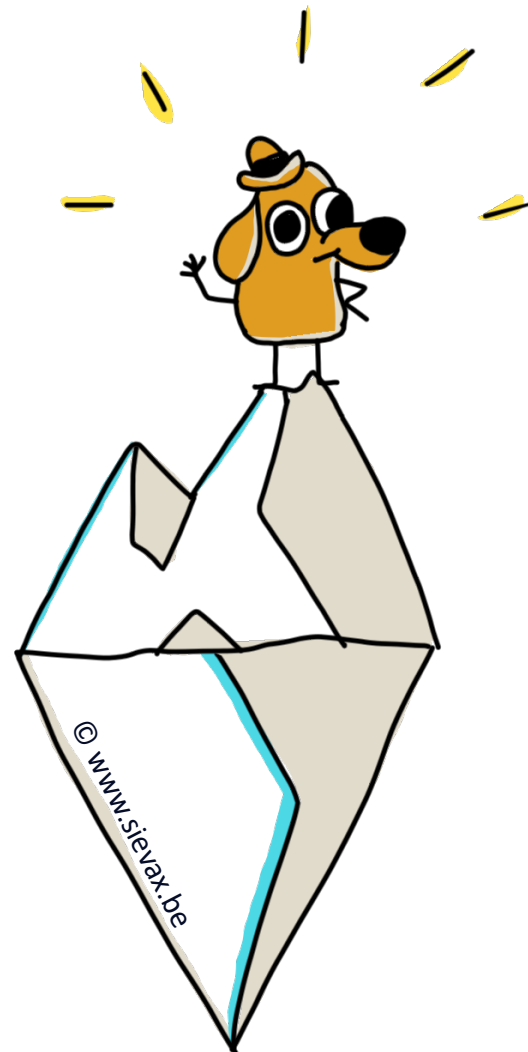
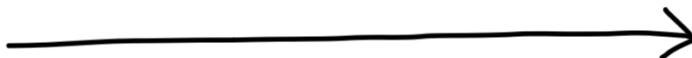
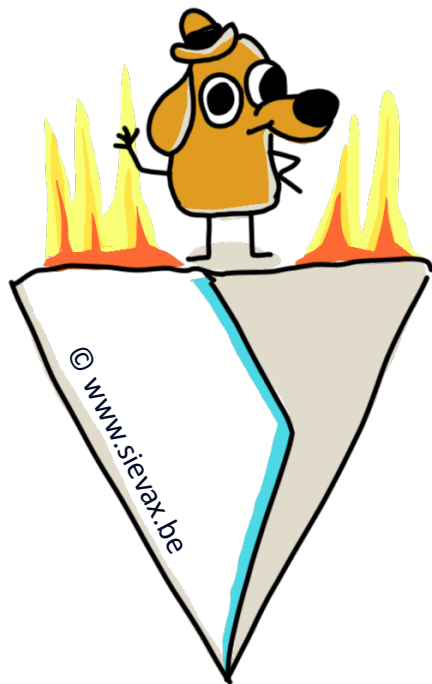

THE DATA ENGINEERING EXPERIENCE

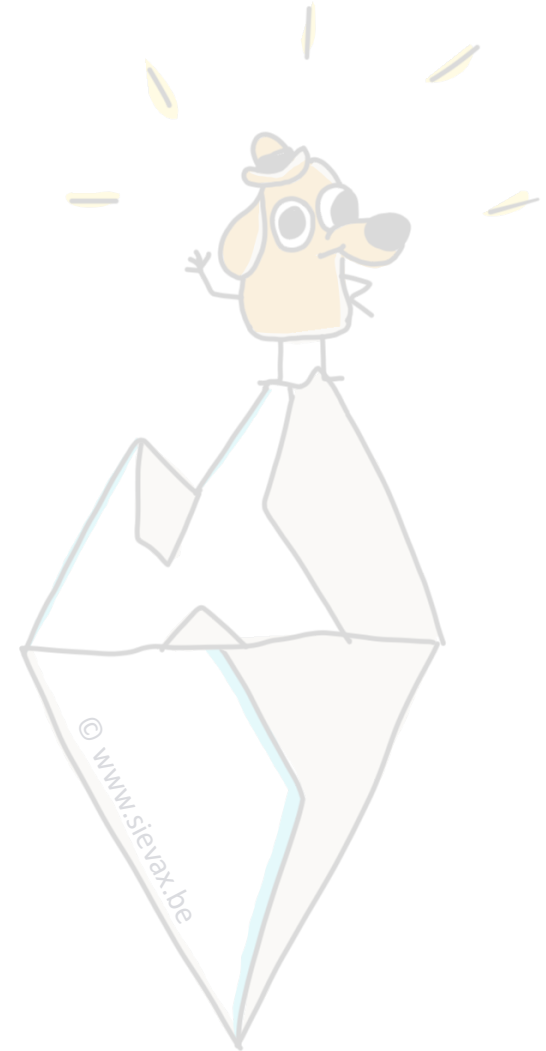
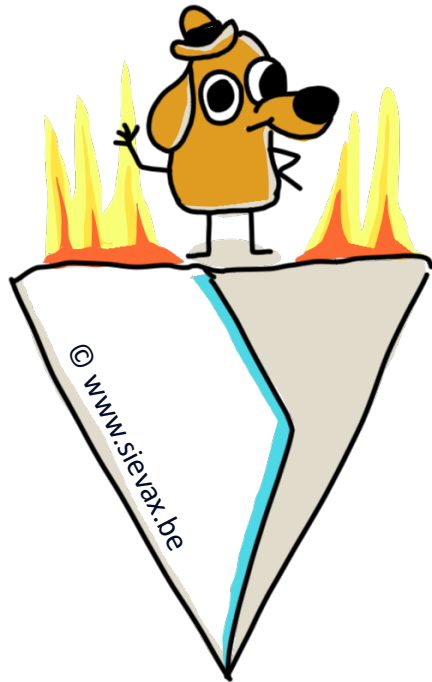

MY IMAGINARY DATA WORLD



MY IMAGINARY DATA WORLD



MY IMAGINARY AI MACHINE

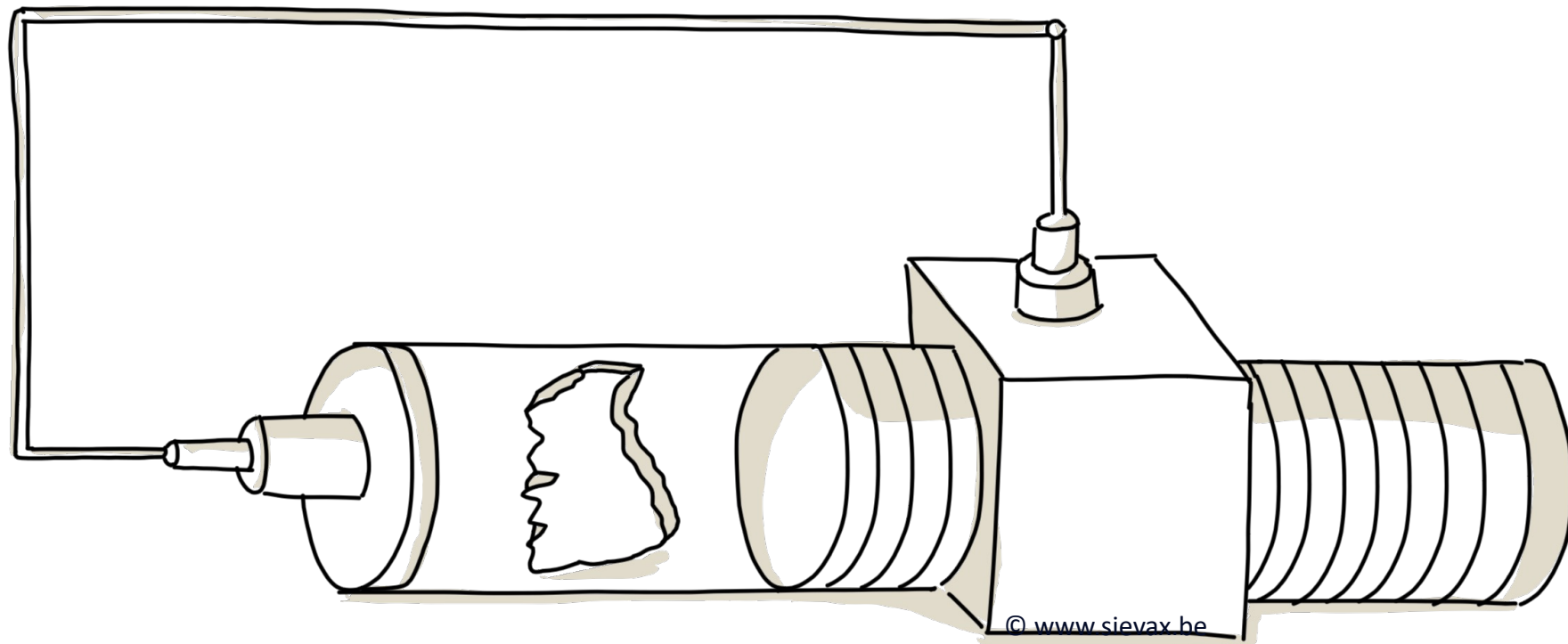

MY IMAGINARY AI MACHINE

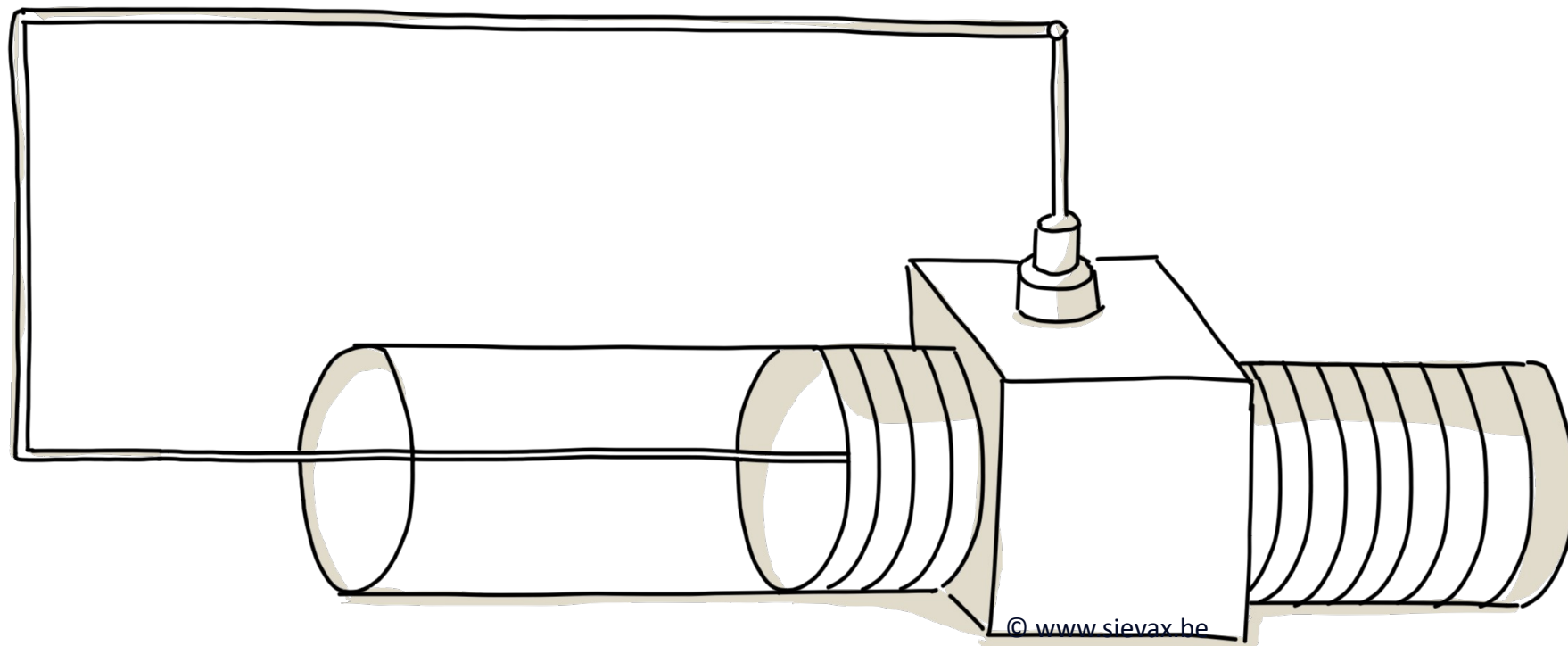

© www.sievax.be

MY IMAGINARY AI MACHINE

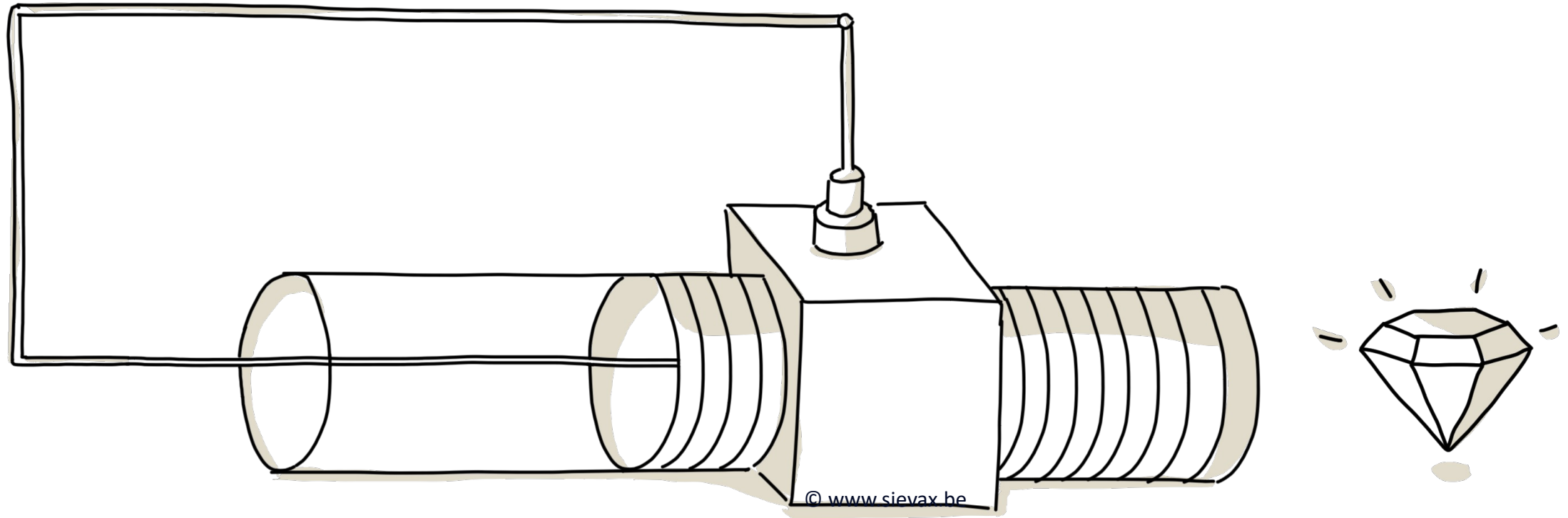

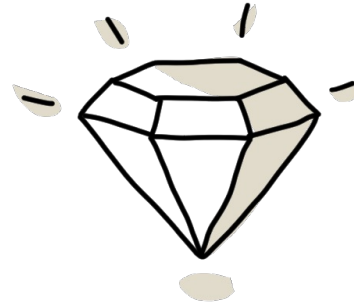
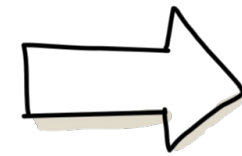
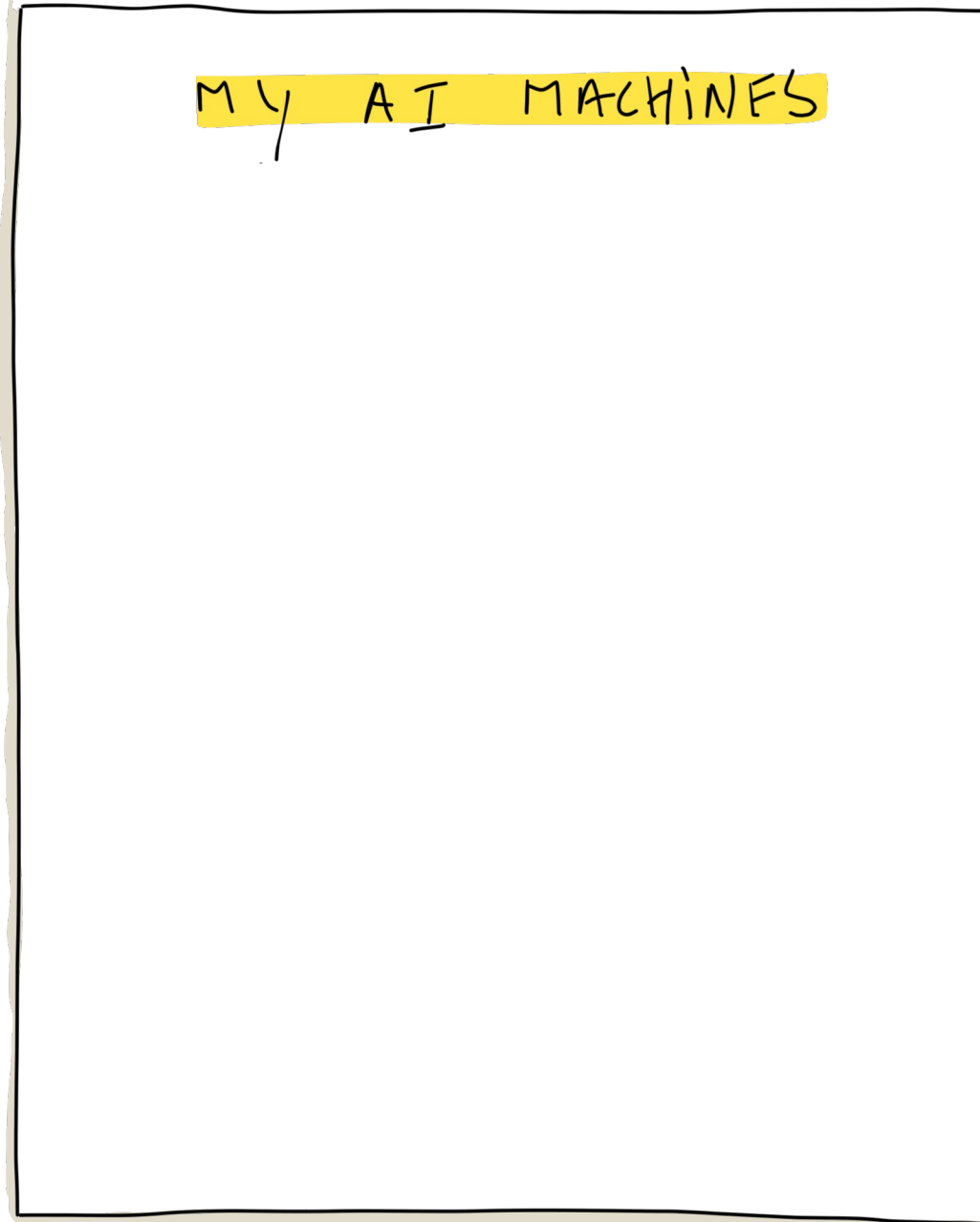
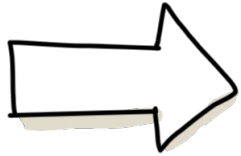
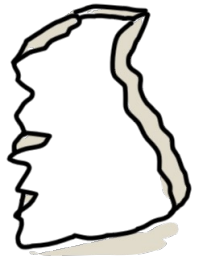

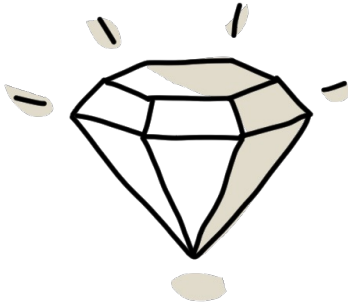
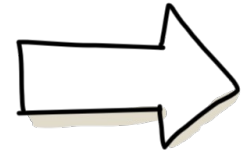
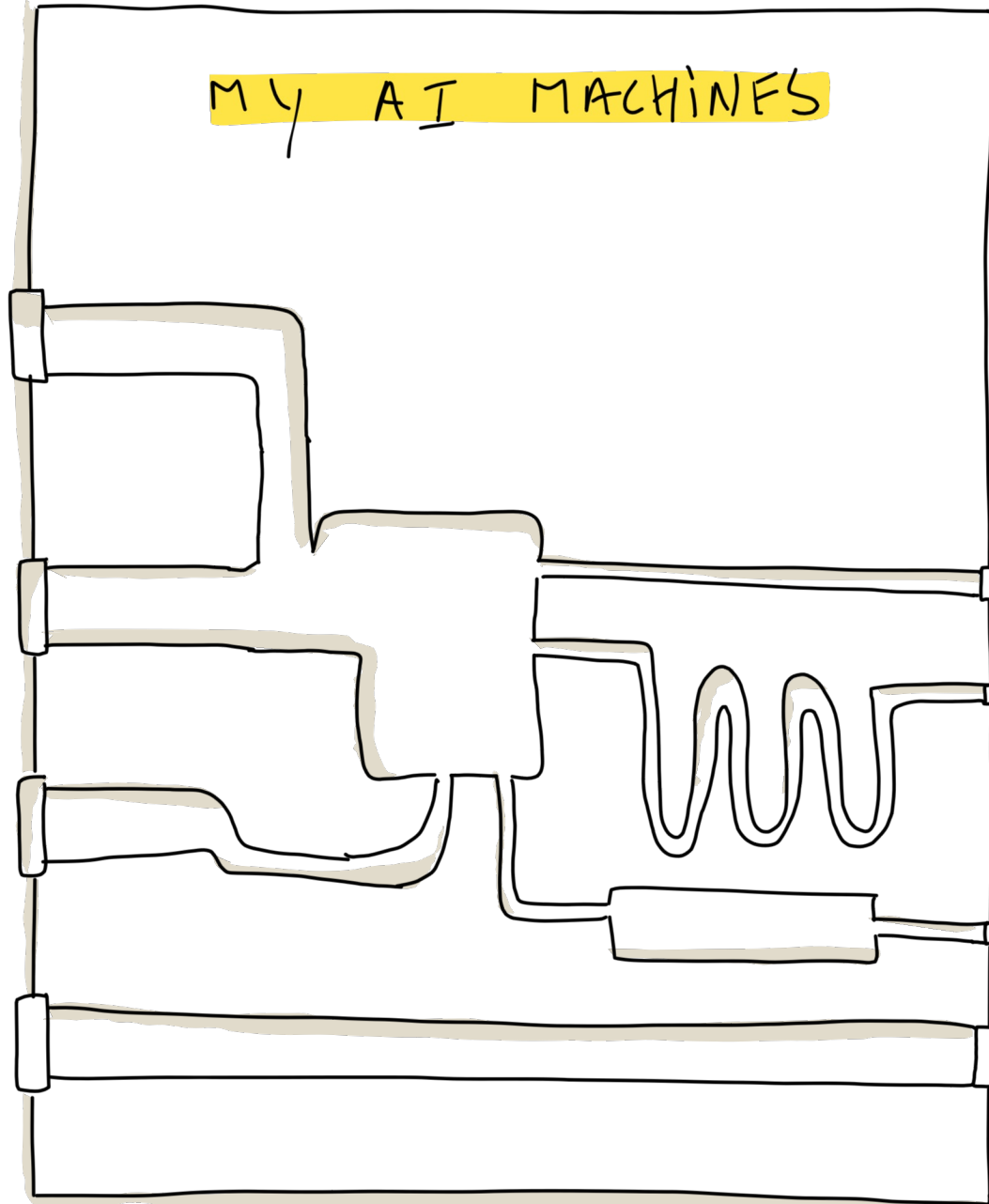
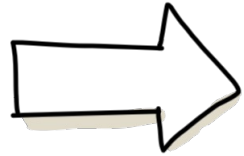
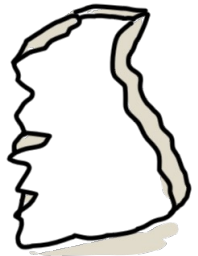

SOME INTROSPECTION...

WERE THESE AI MACHINES A **SUCCESS**?

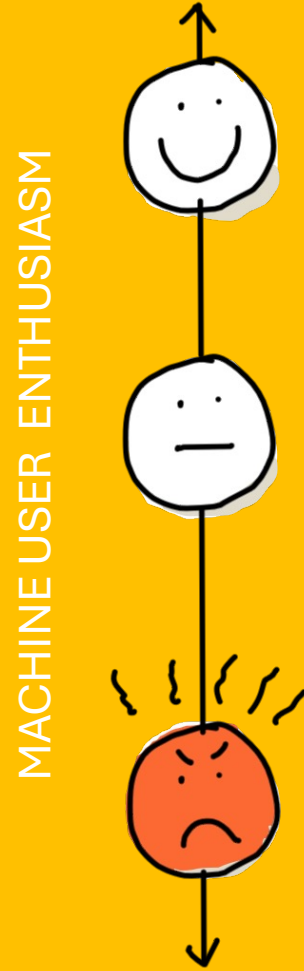

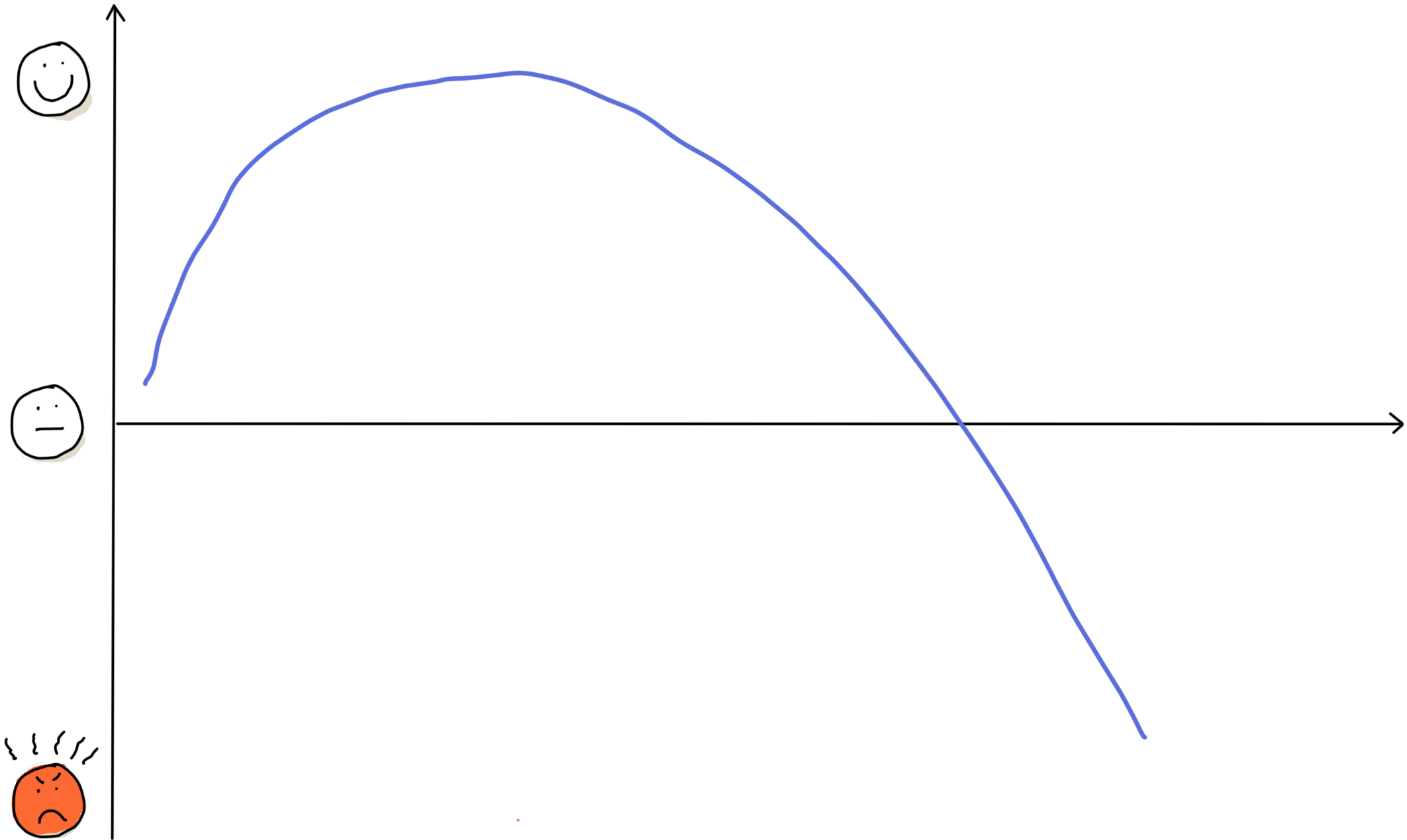

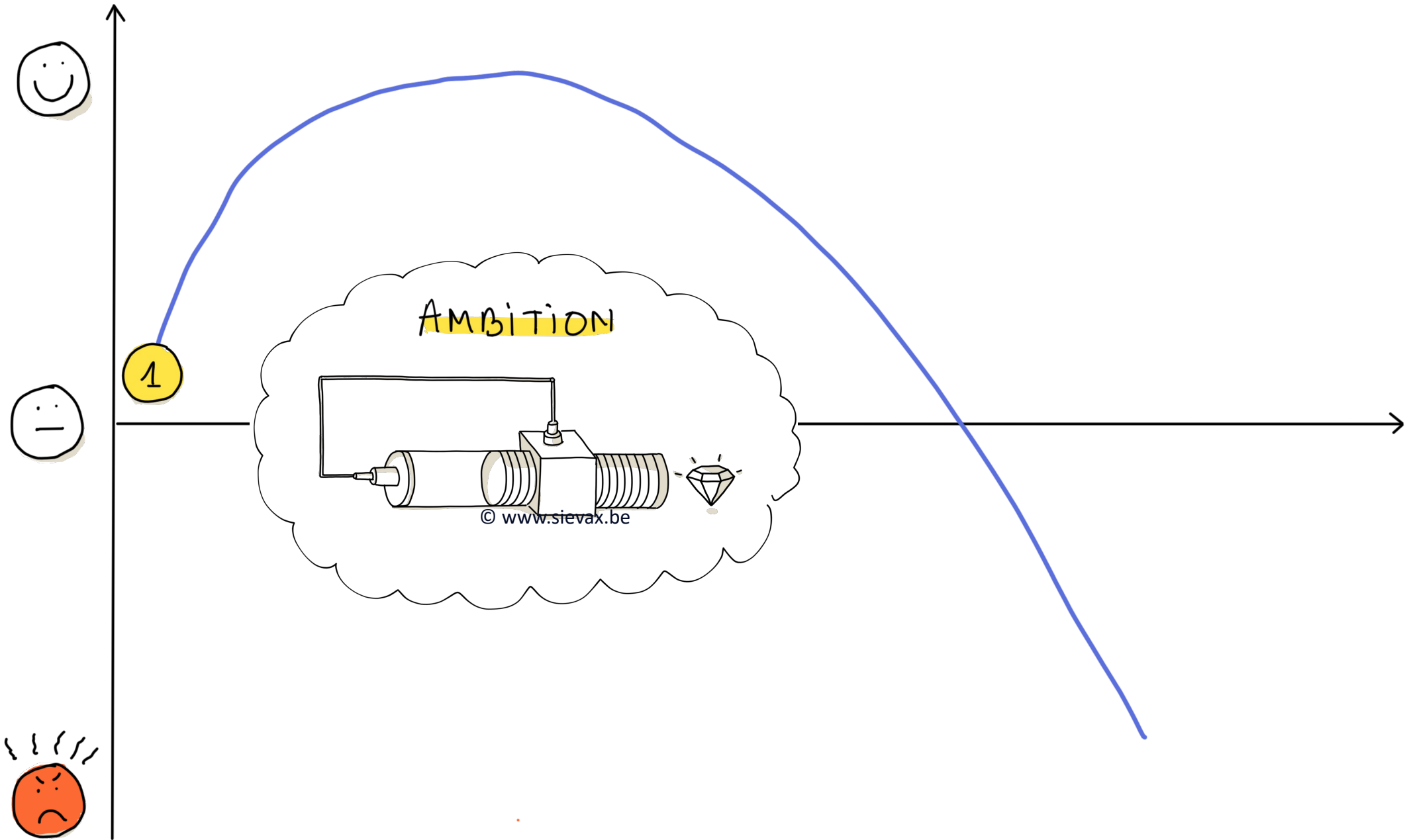

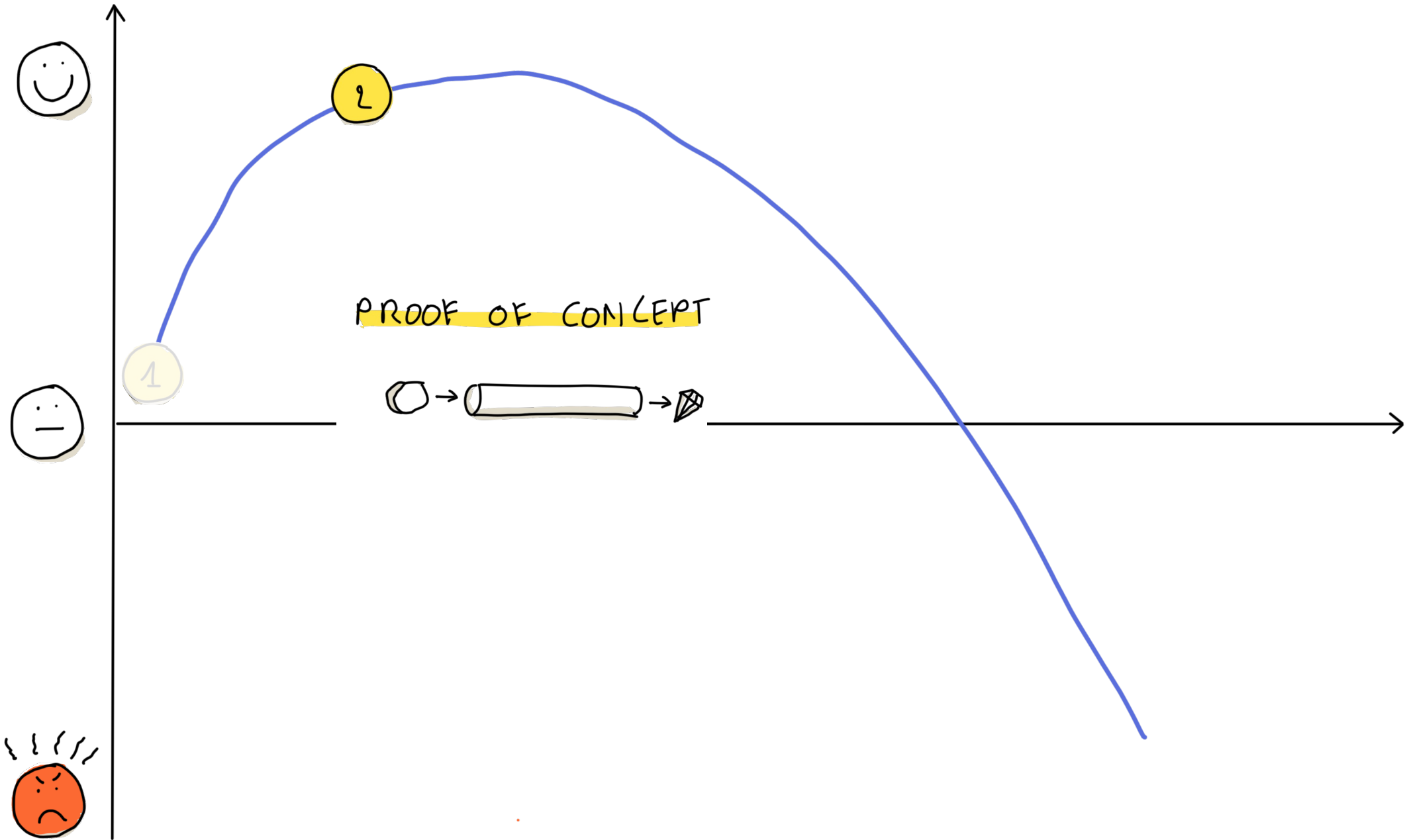

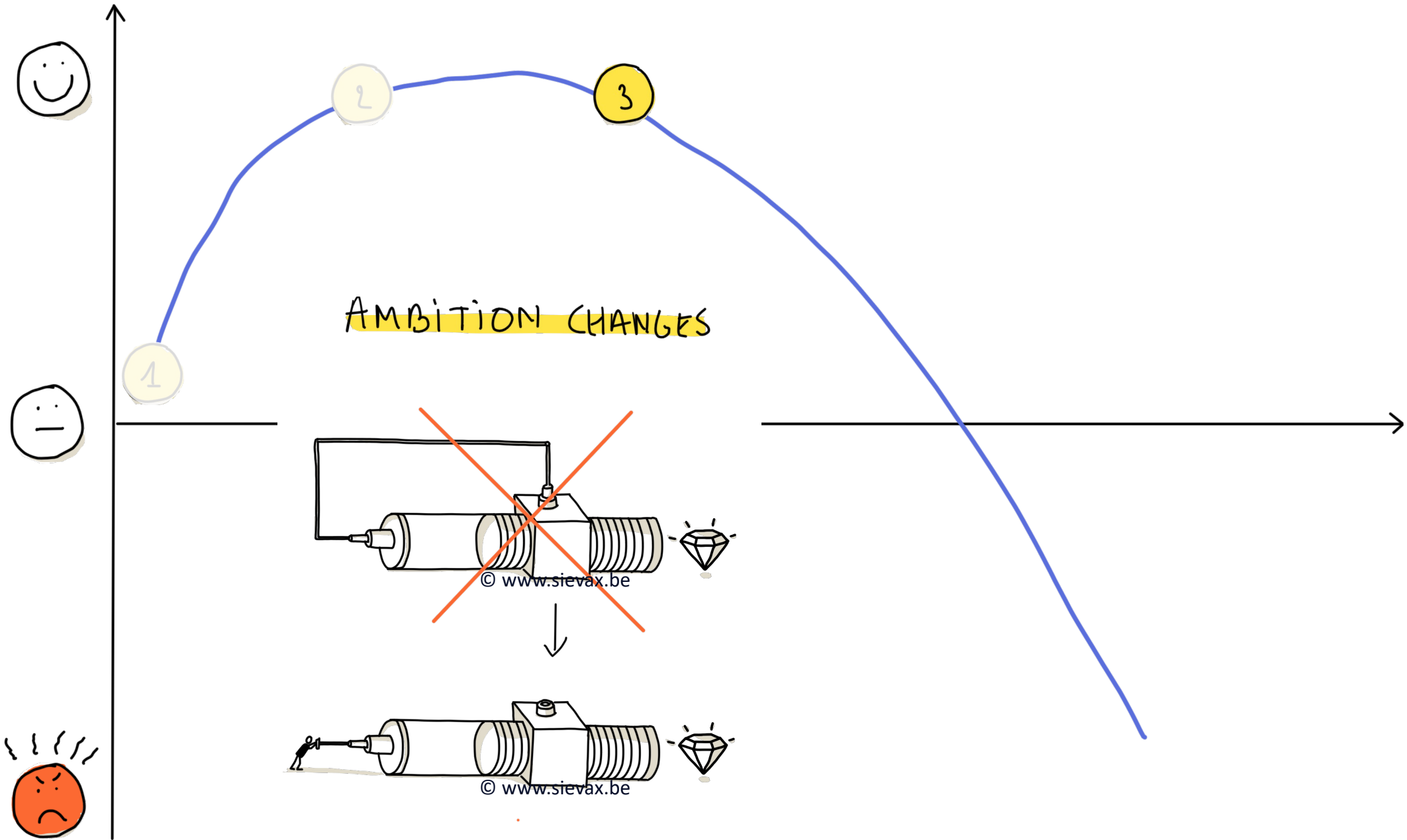

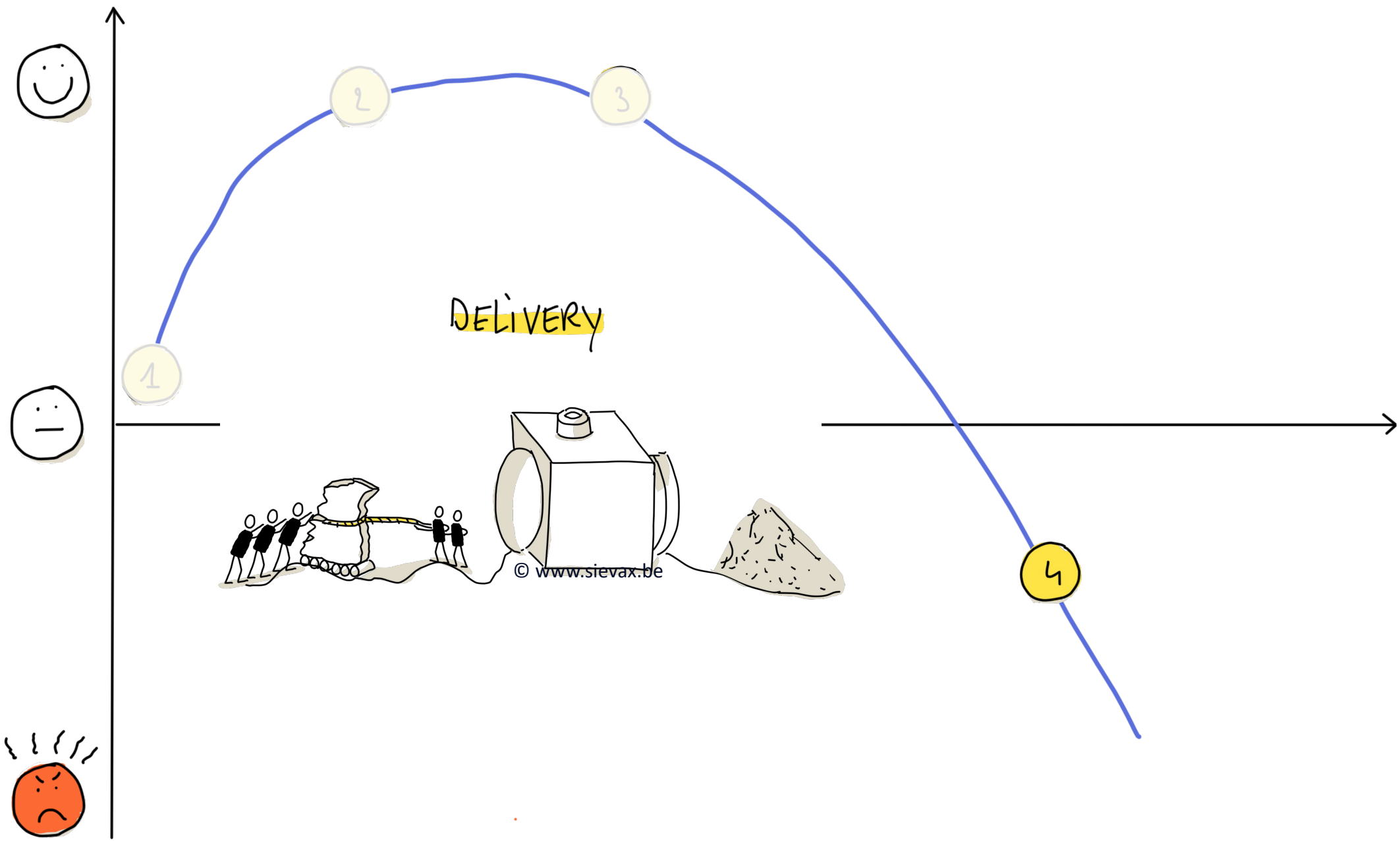

DELIVERY

© www.sievax.be



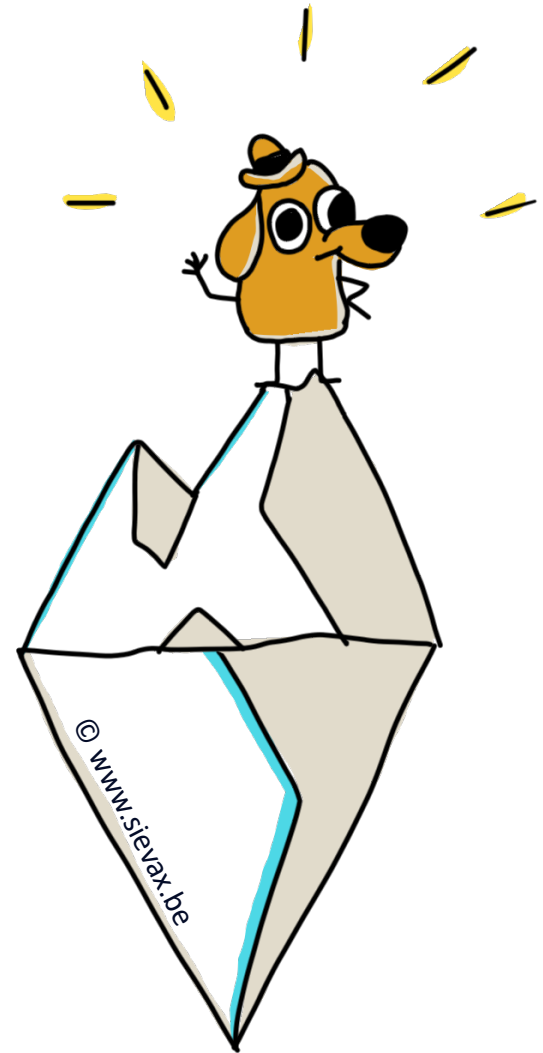

MY JOURNEY TOWARDS VALUE FROM AI

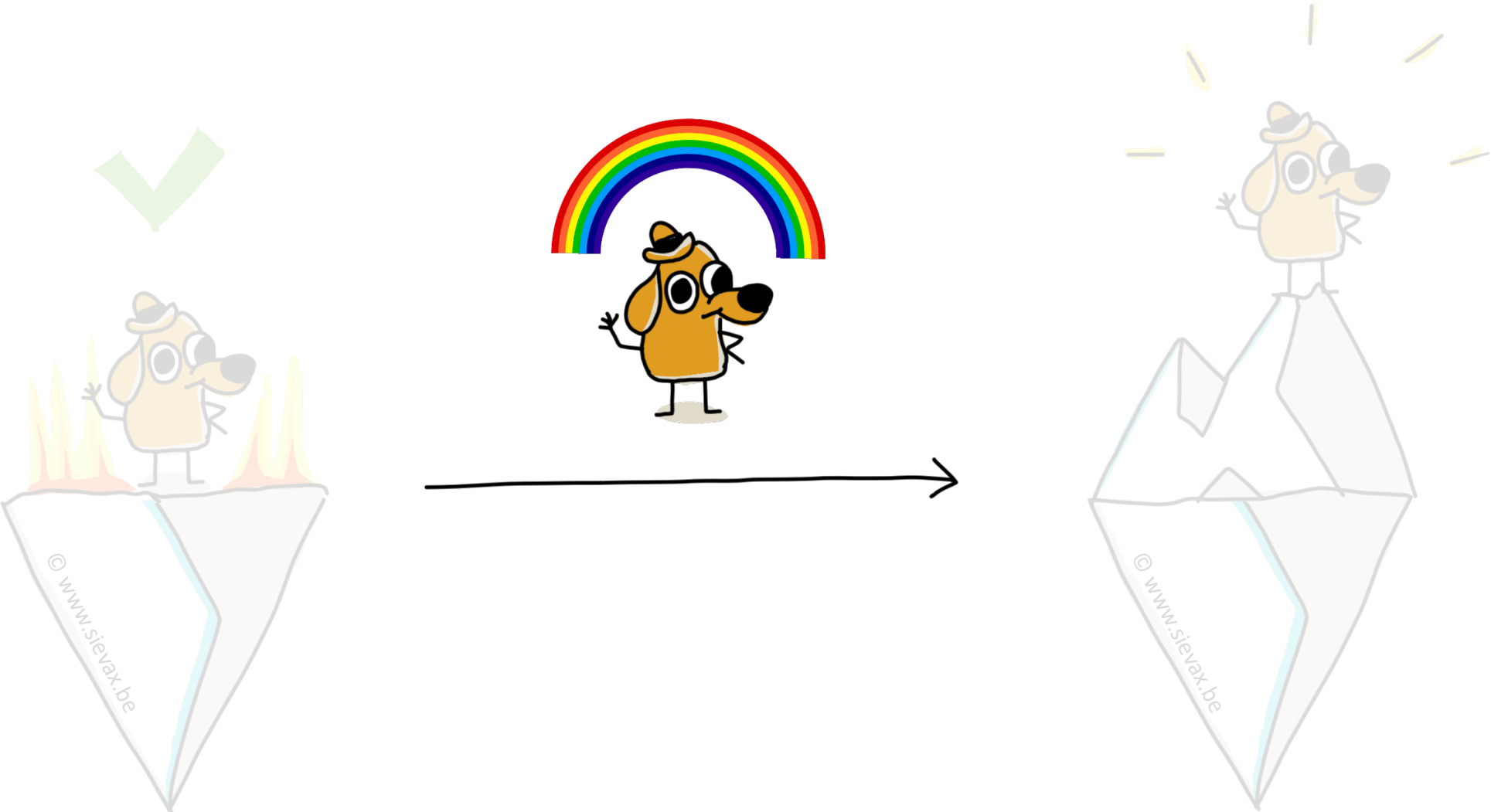

MY JOURNEY TOWARDS VALUE FROM AI

I

II

III

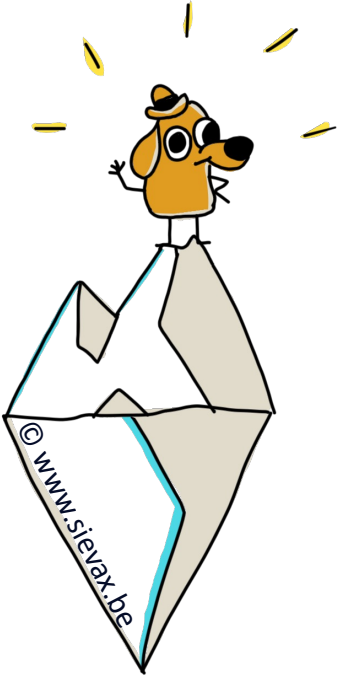
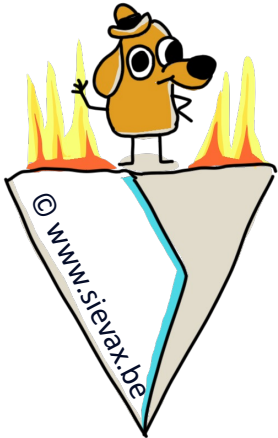
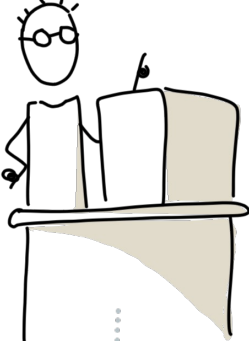
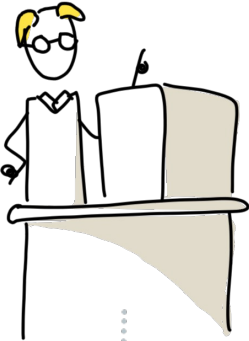
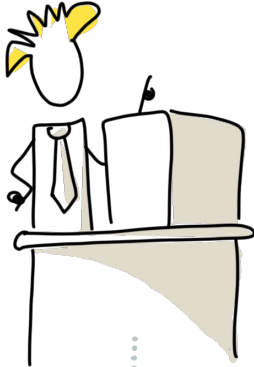

THE DATA GOVERNANCE APPROACH

I

II

III

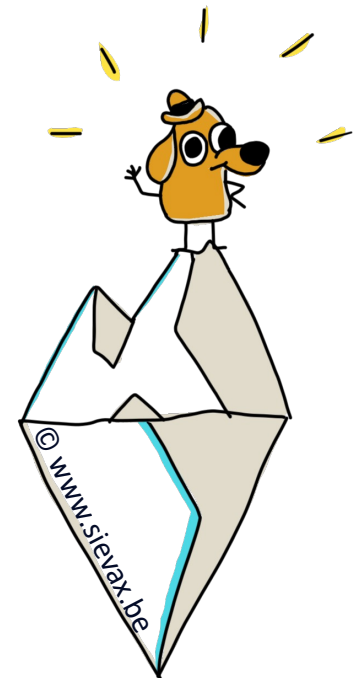
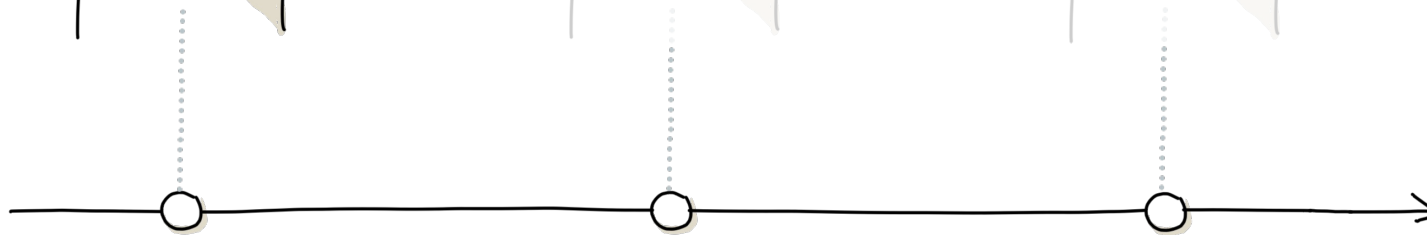
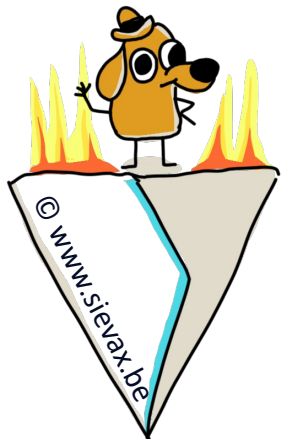



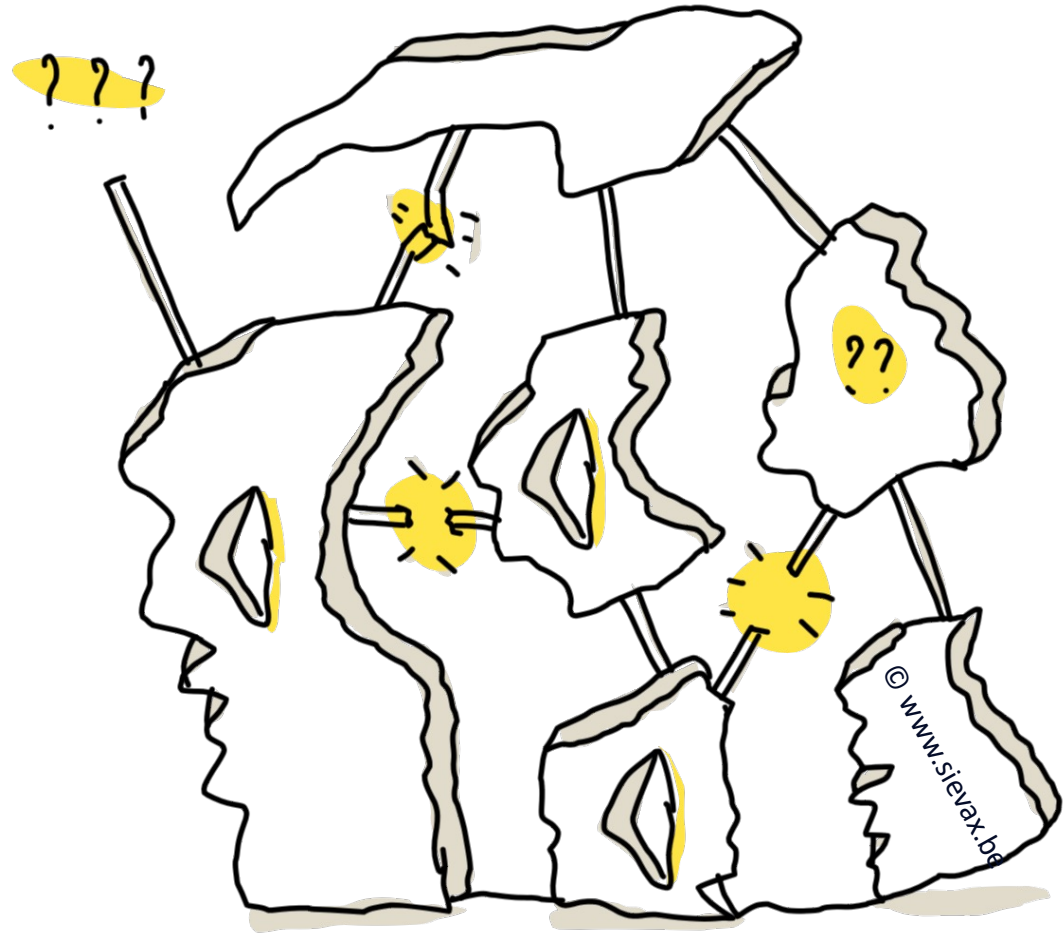

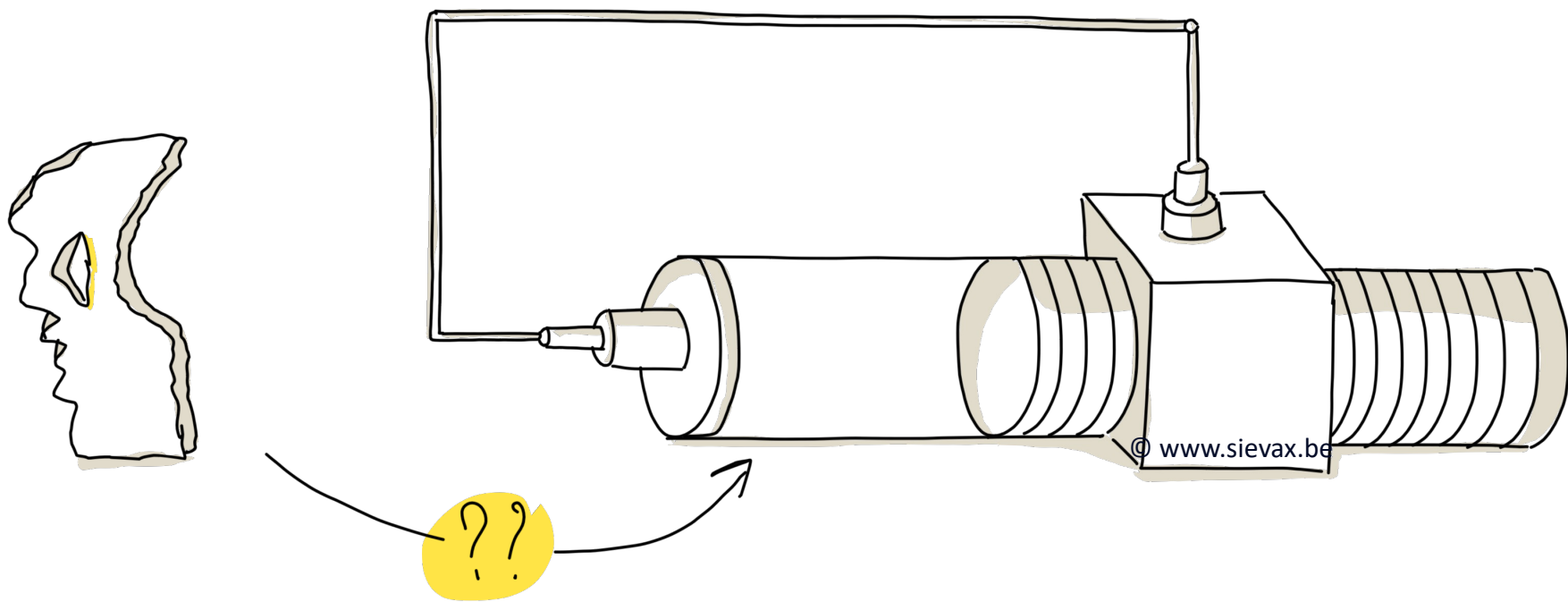

DATA? WHICH DATA?

**ENTER: DATA
GOVERNANCE**

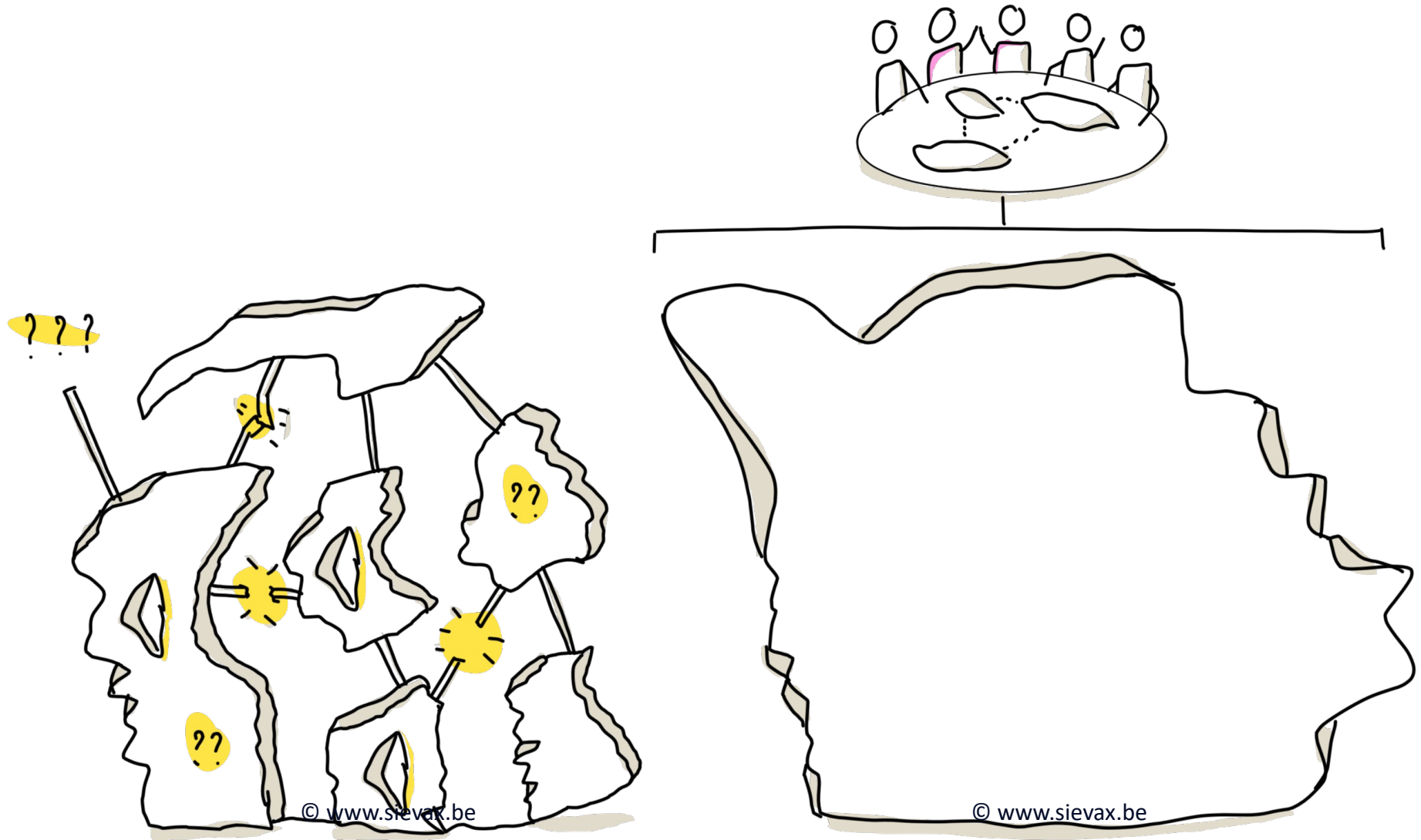

THE DATA

THE MODEL

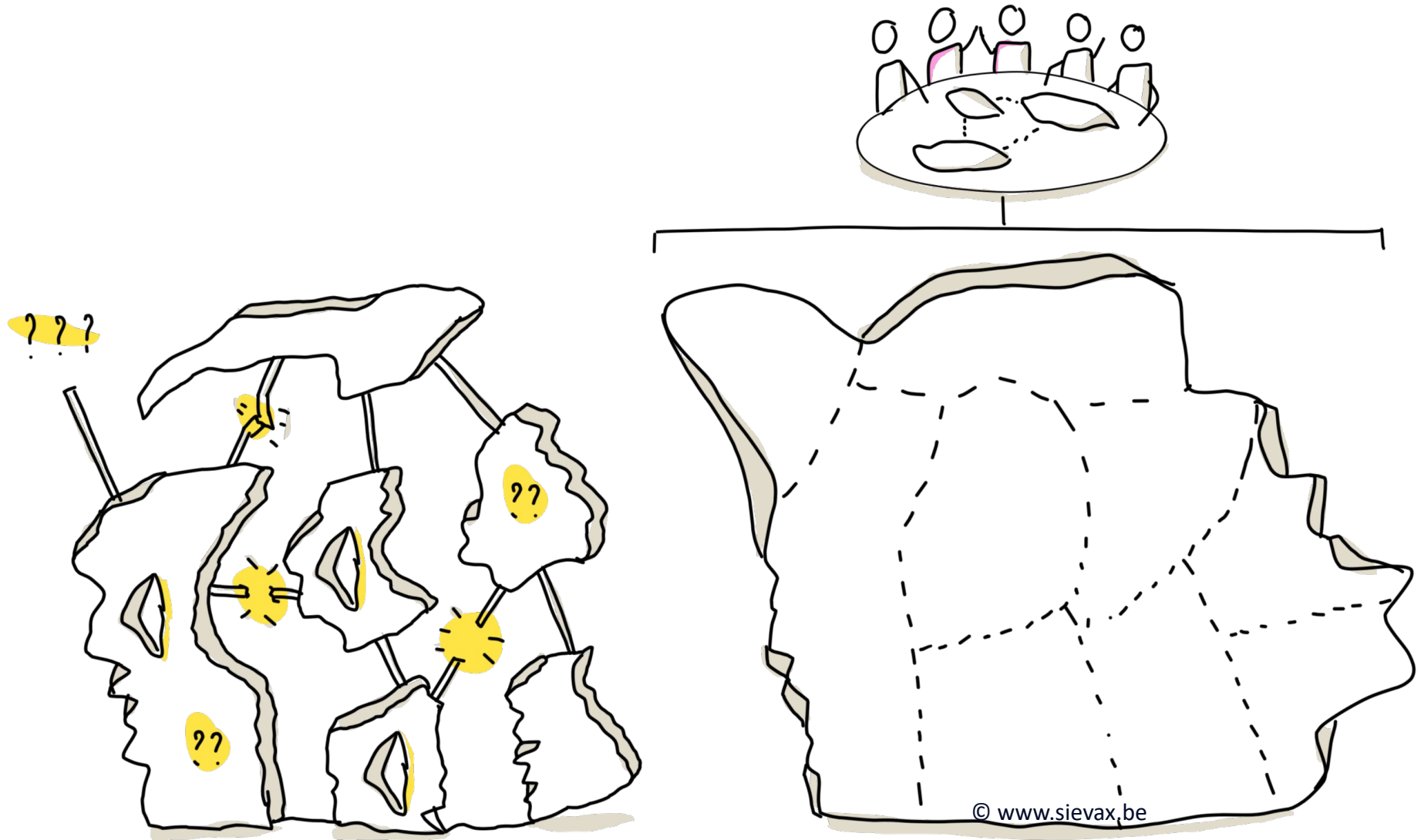

THE DATA

THE MODEL

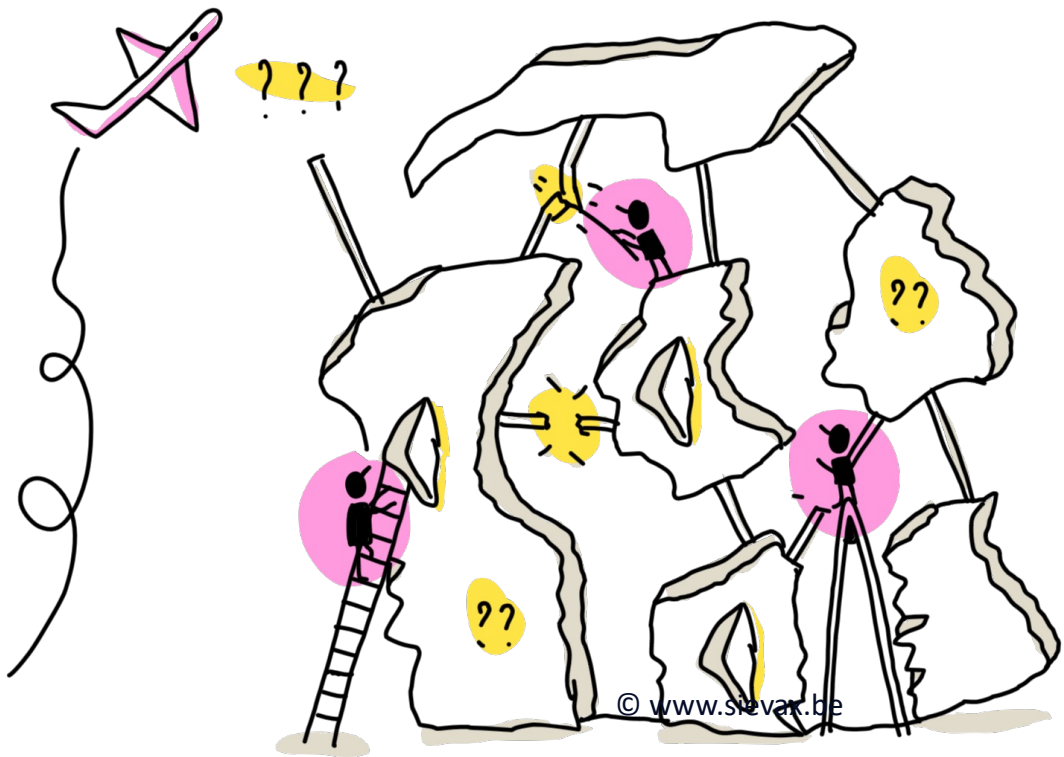

THE ENHANCED DATA

© www.sievax.be

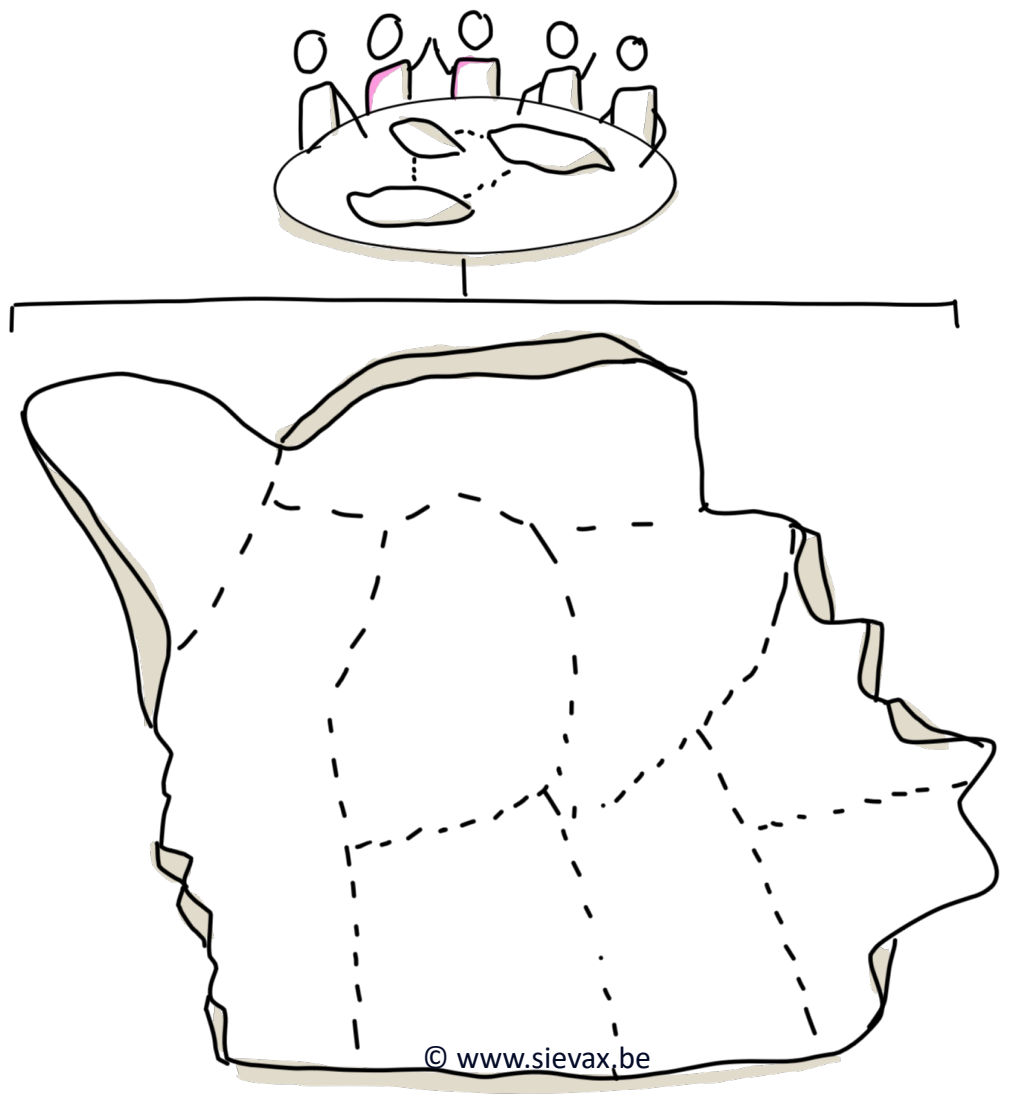

THE MODEL

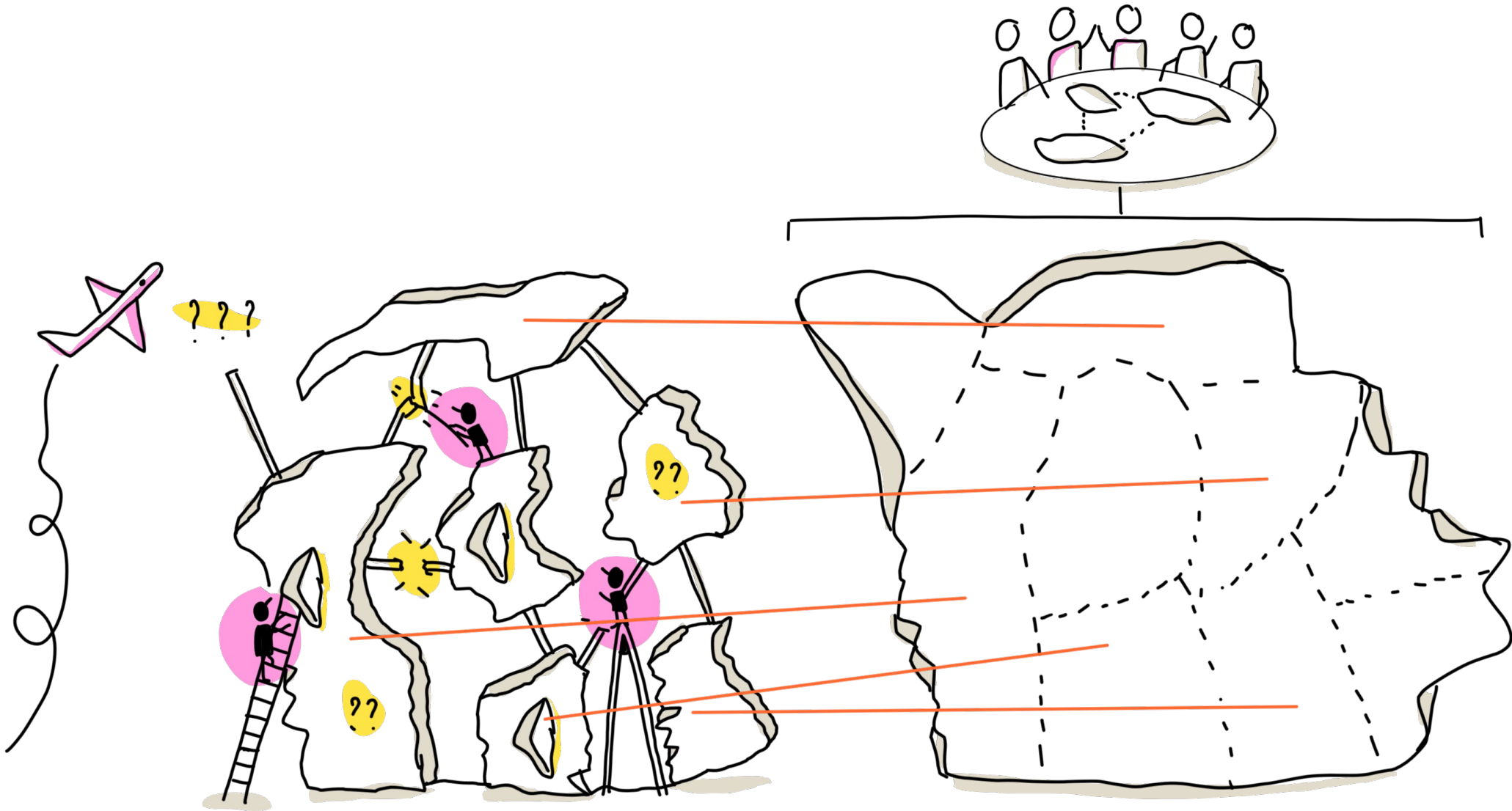

THE ENHANCED DATA

THE MODEL

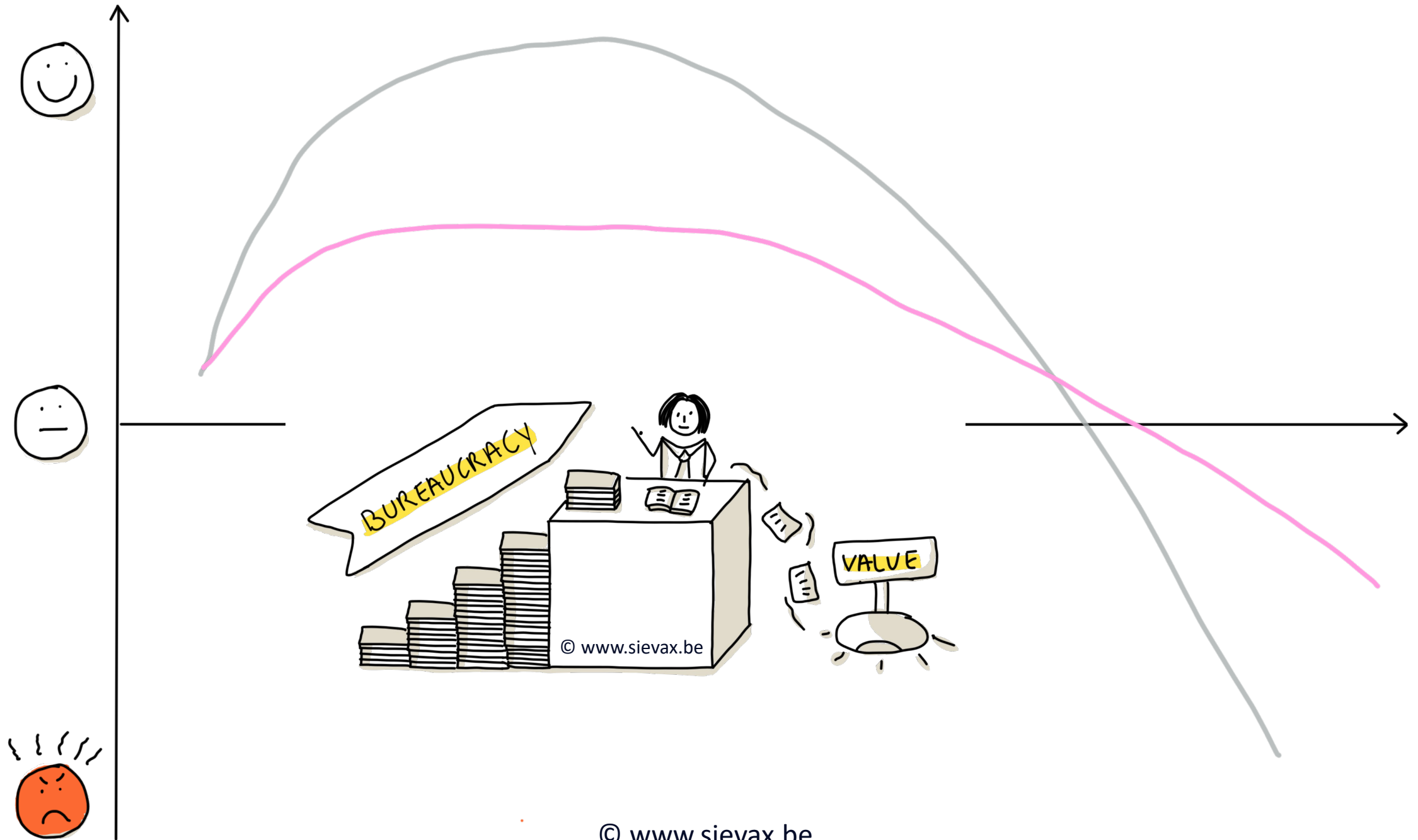

THE DATA PRODUCT APPROACH

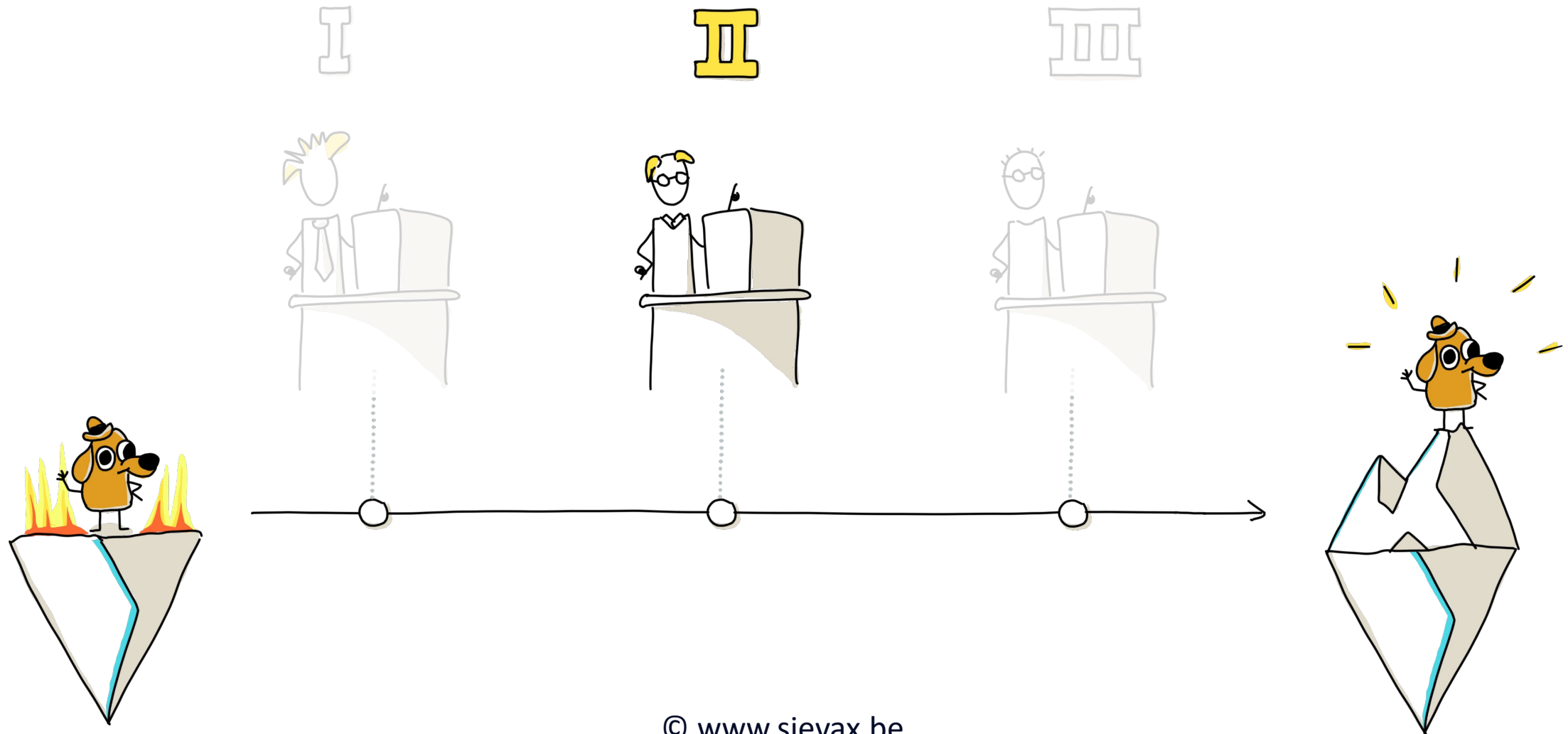

How to Eat an Elephant?

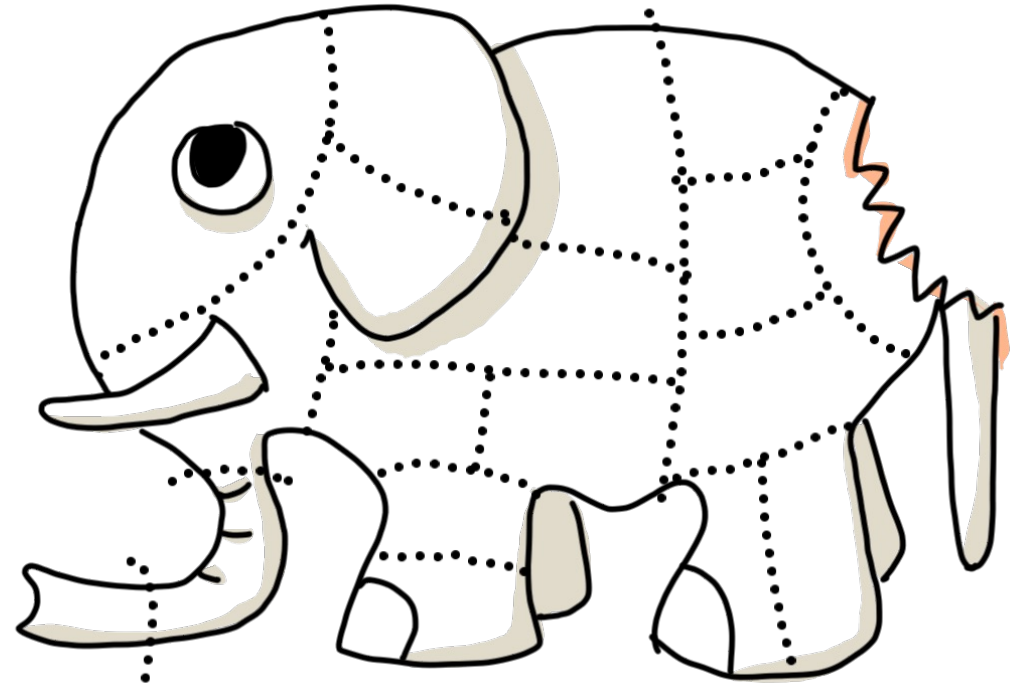
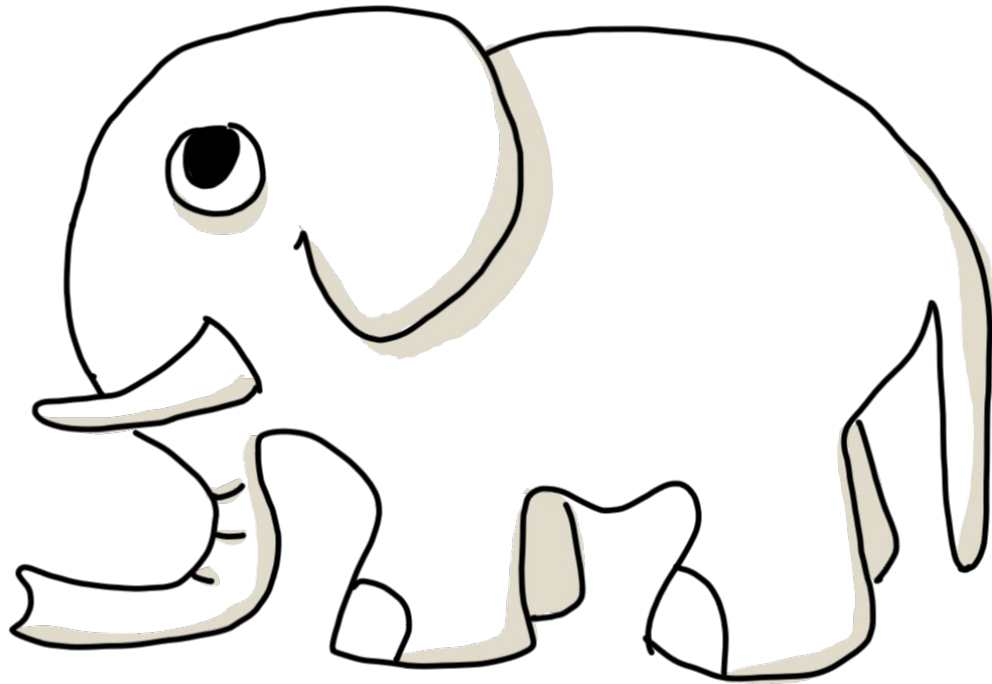

One bite at a time

How to start a **Data Governance Program?**

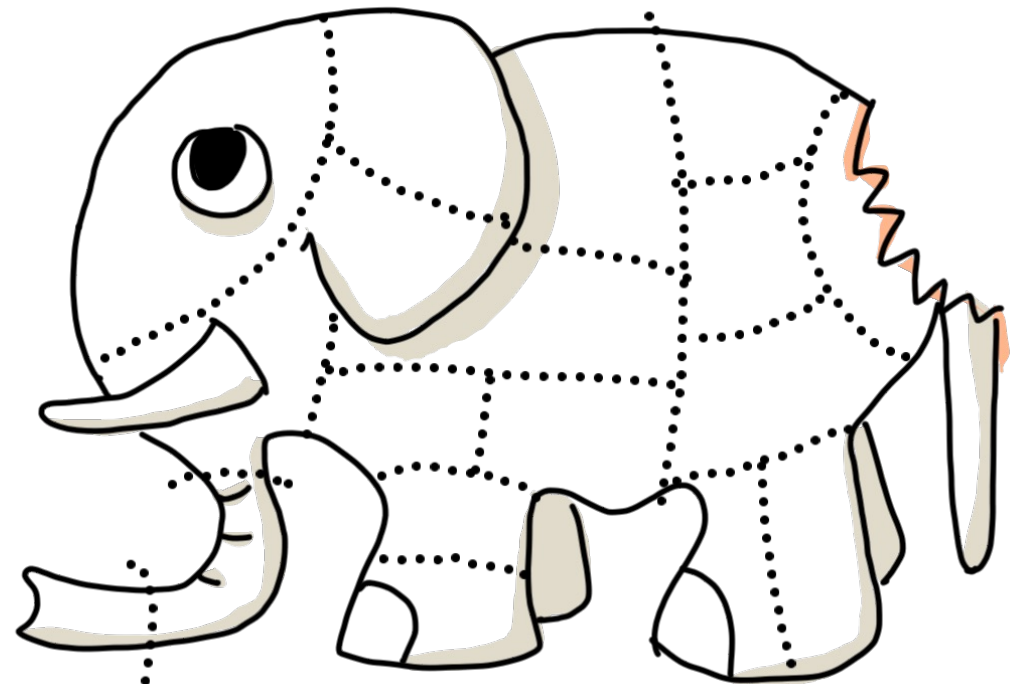
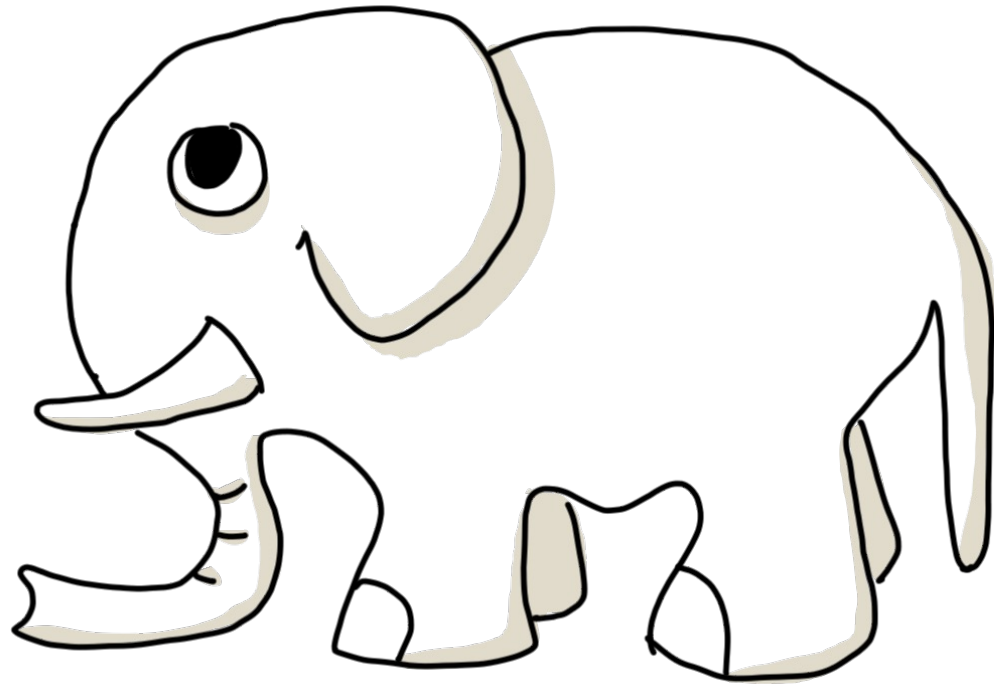

Piece by Piece

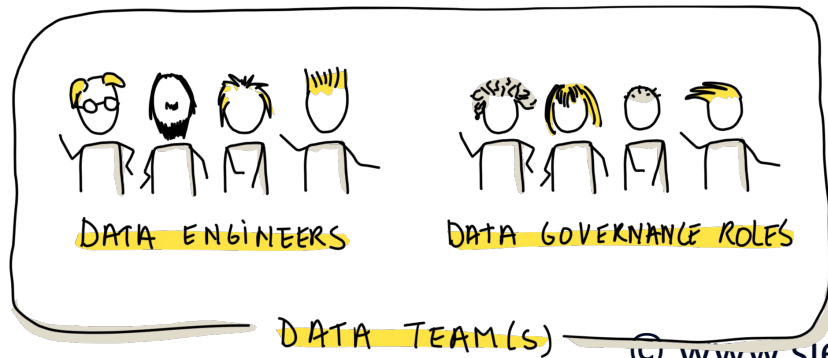
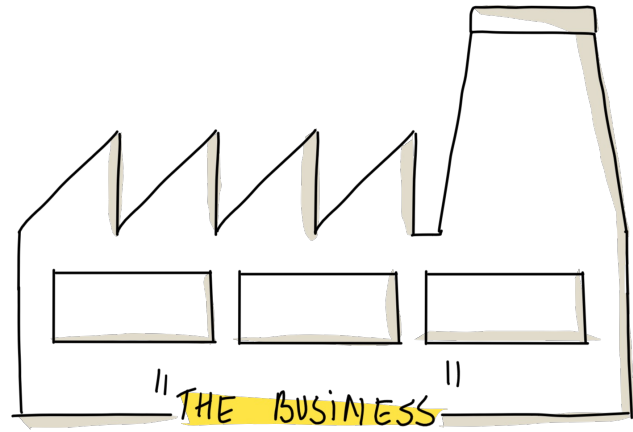

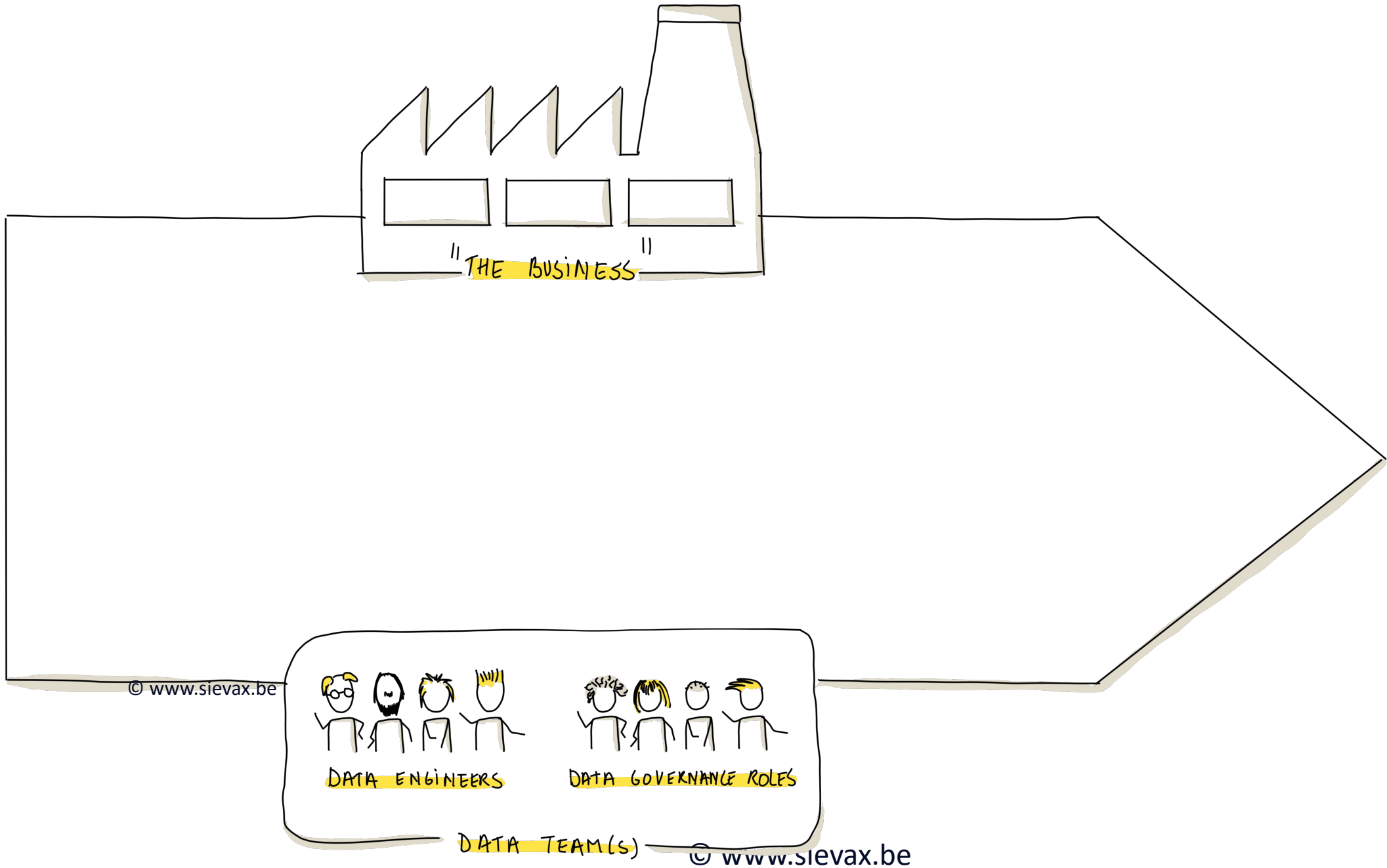

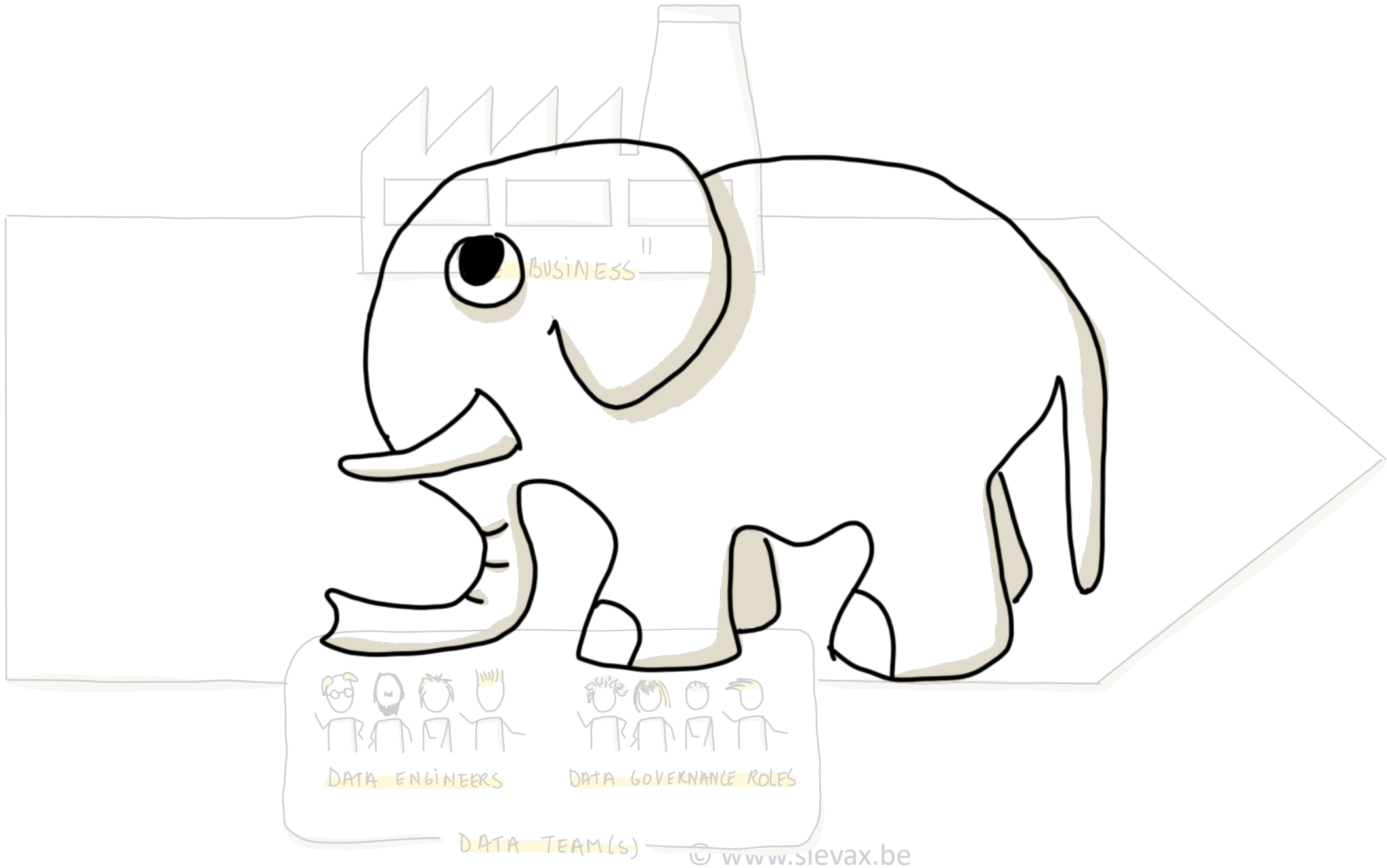

DATA TEAM(S)

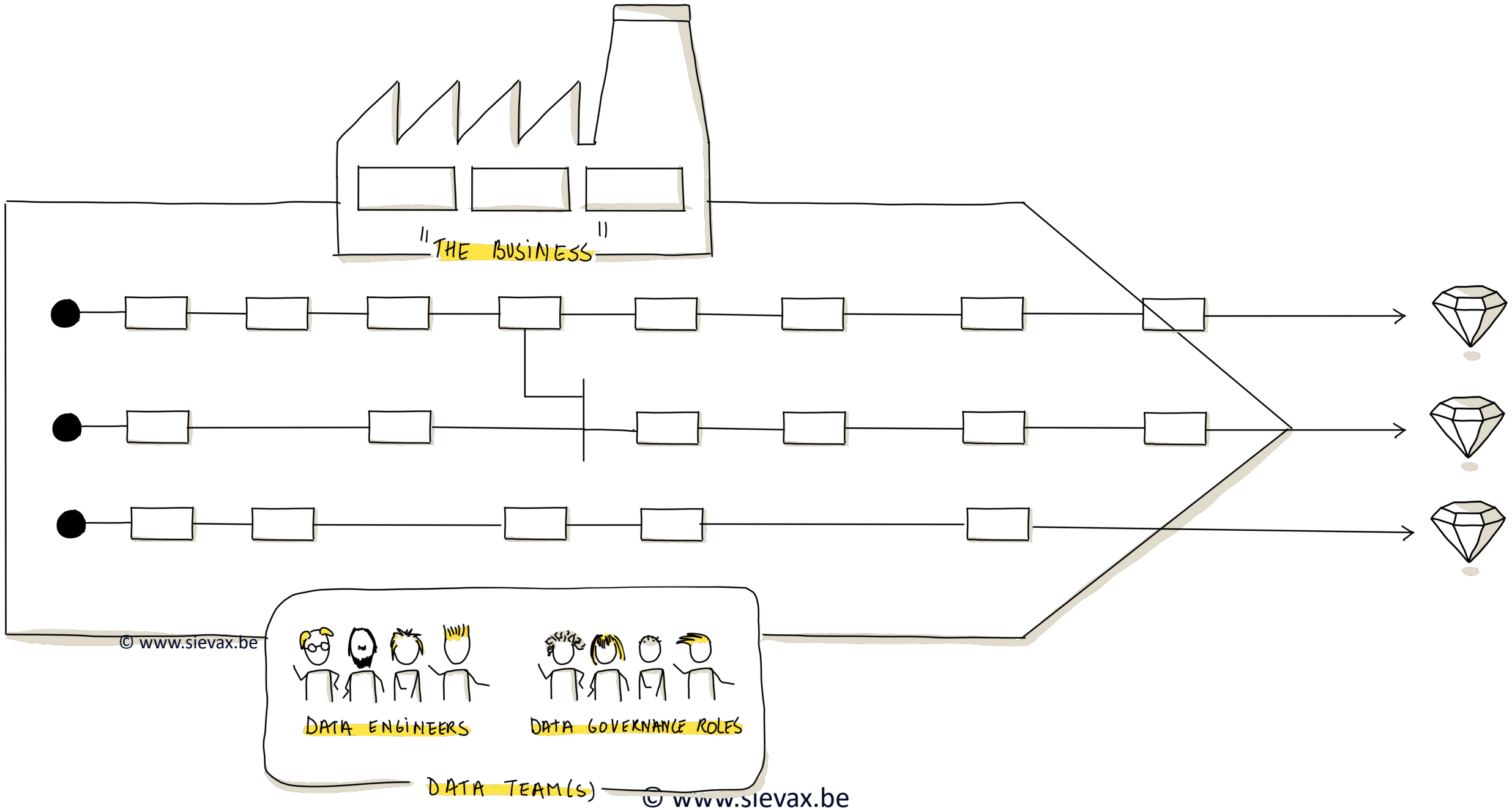

"THE BUSINESS"

DATA ENGINEERS

DATA GOVERNANCE ROLES

DATA TEAM(S)

© www.sievax.be

© www.sievax.be

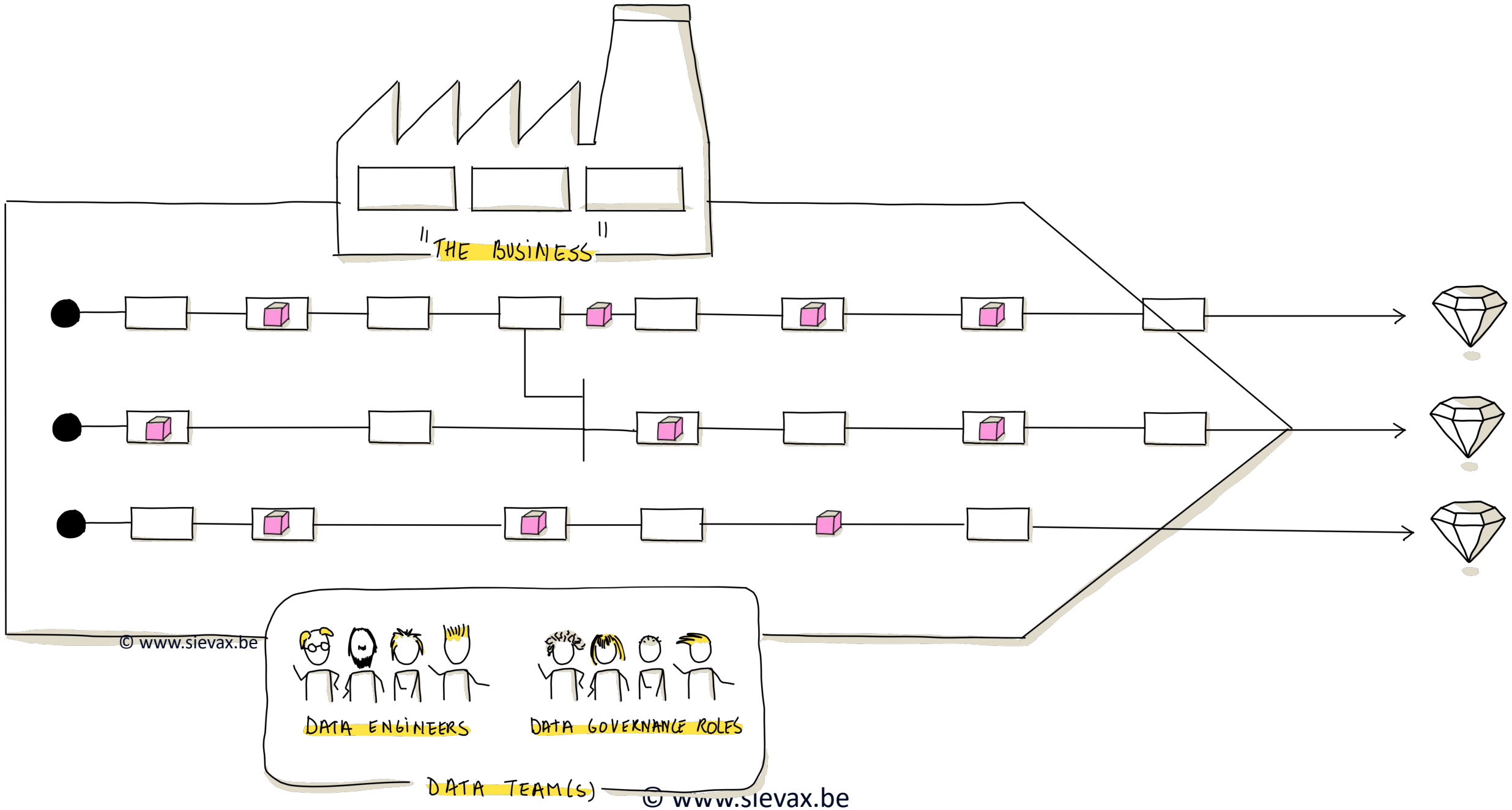

© www.sievax.be



DATA ENGINEERS



DATA GOVERNANCE ROLES

DATA TEAM(S)

© www.sievax.be

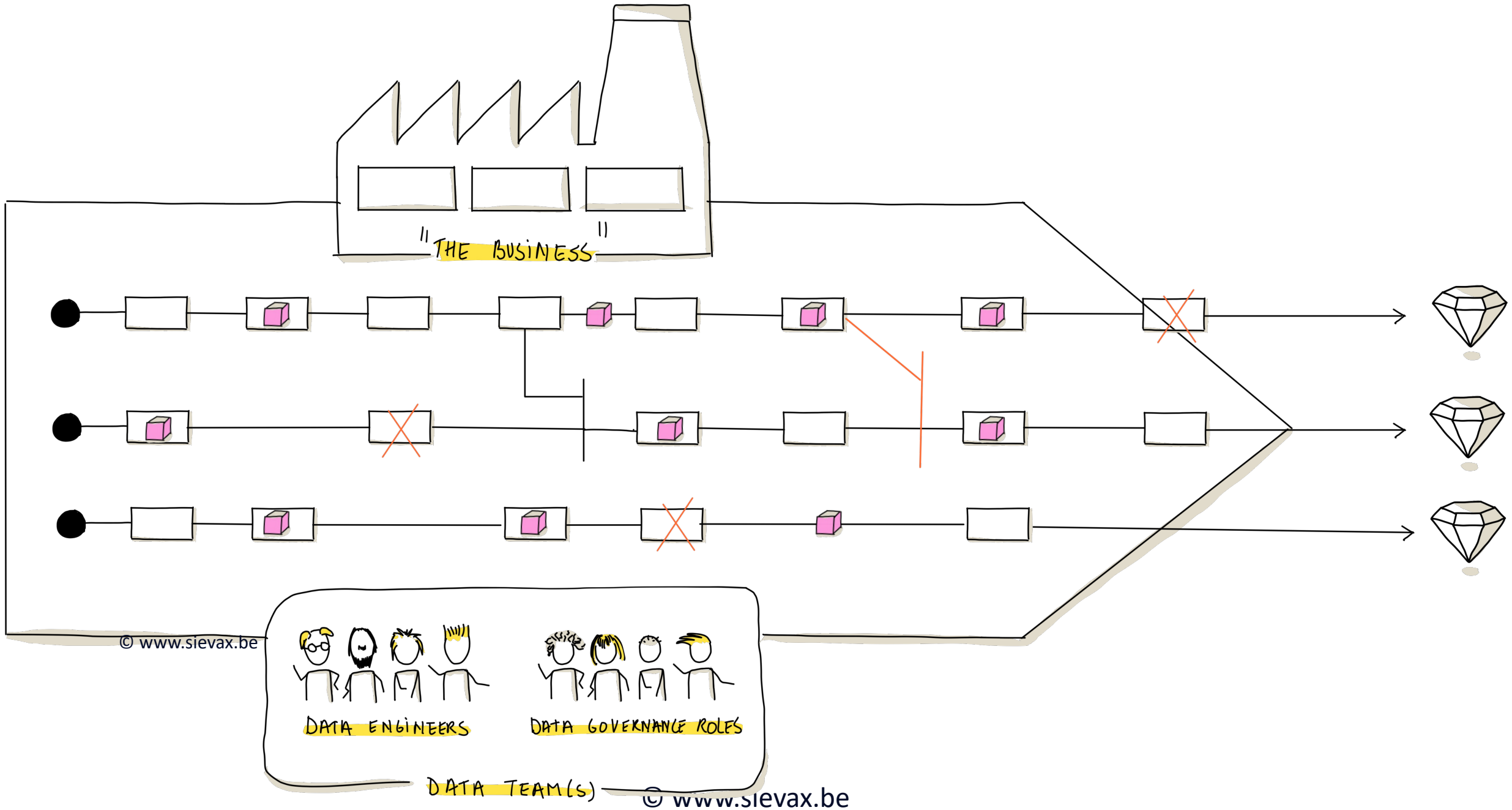

© www.sievax.be



DATA ENGINEERS



DATA GOVERNANCE ROLES

DATA TEAM(S)

© www.sievax.be

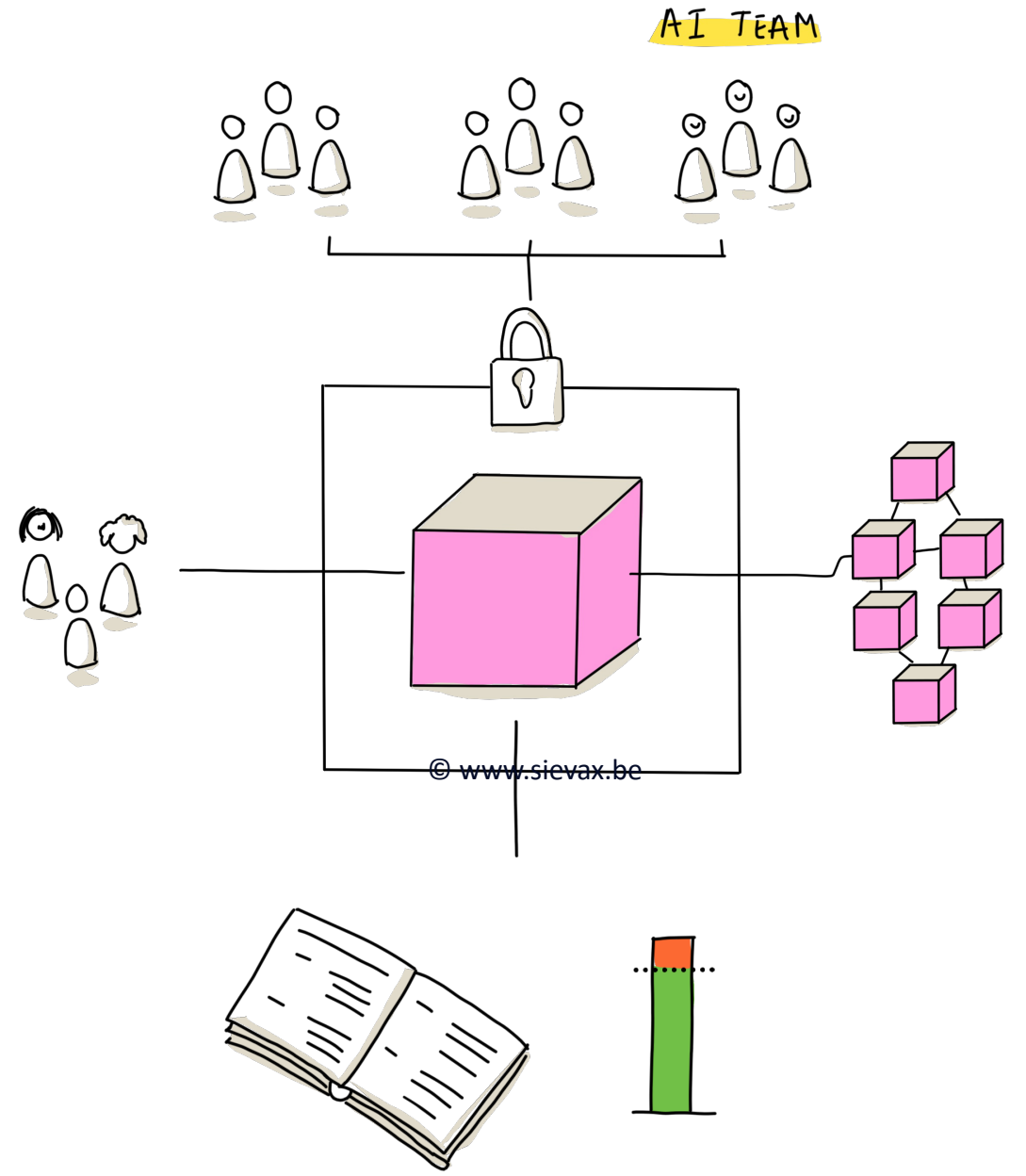
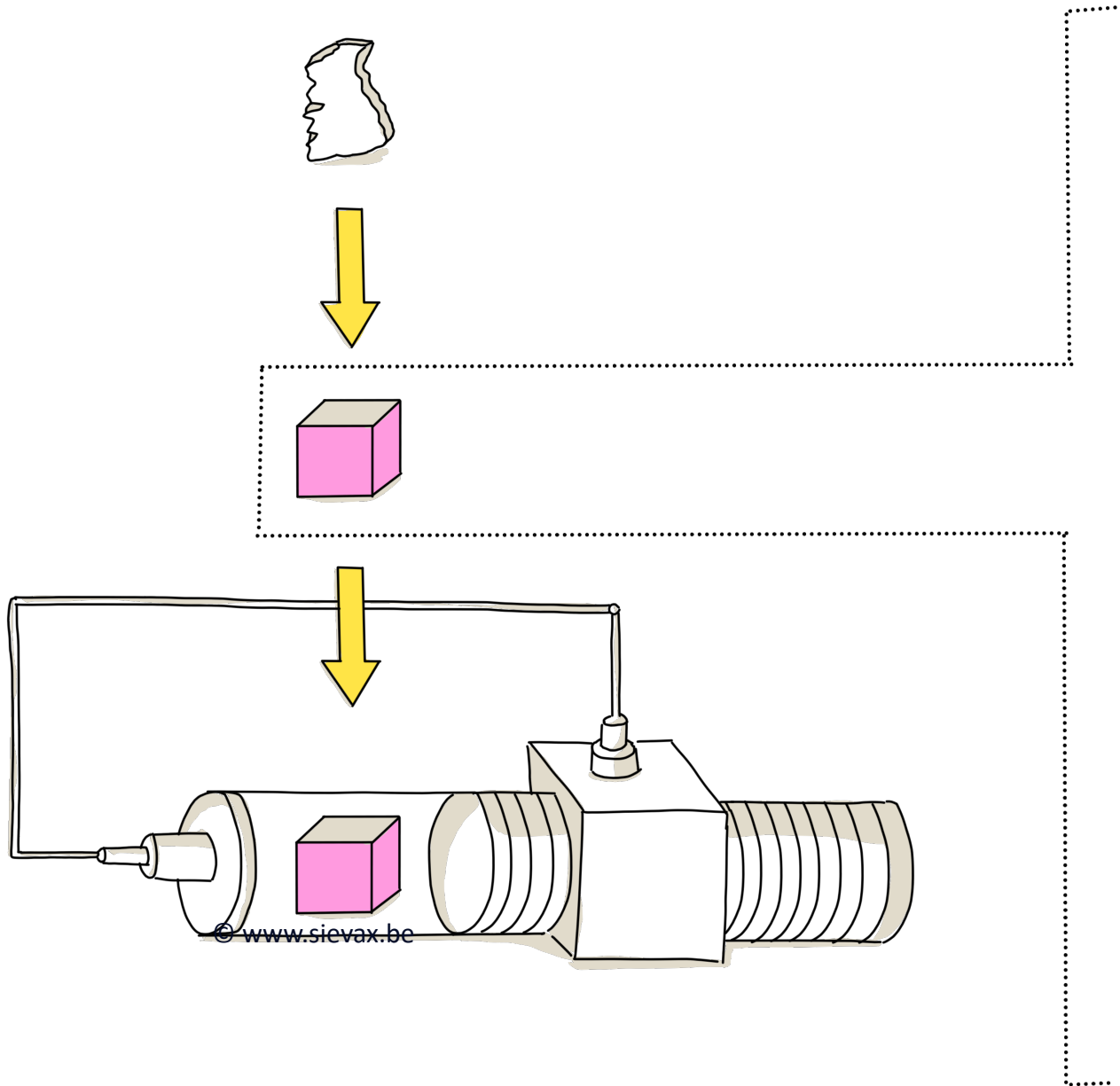

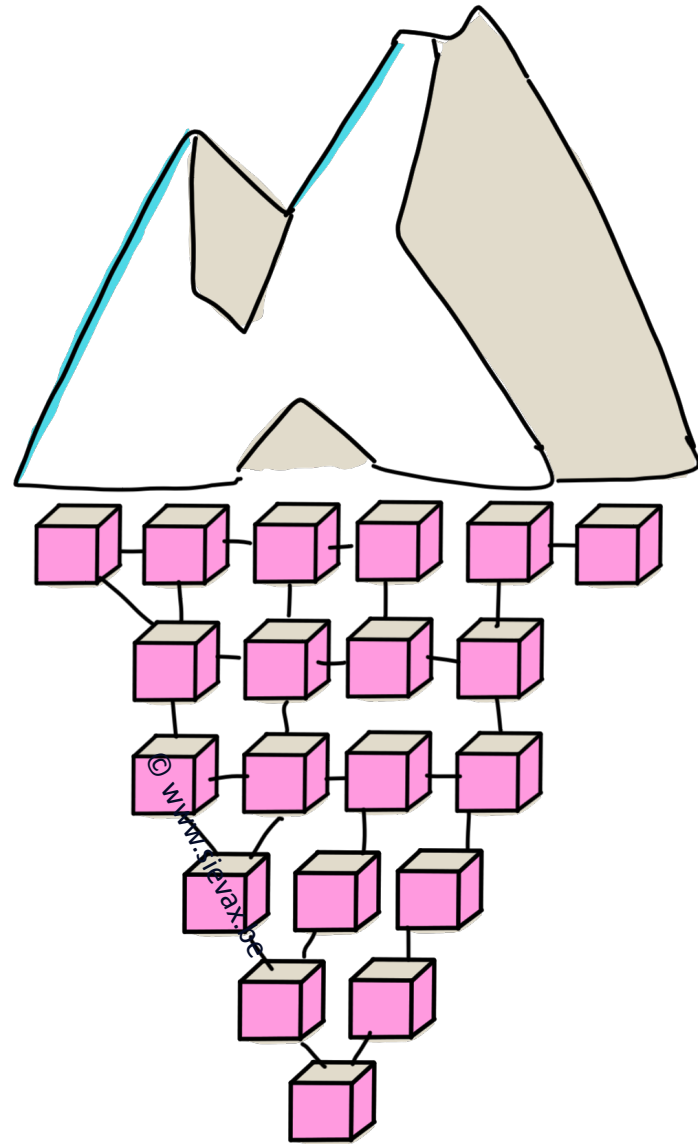
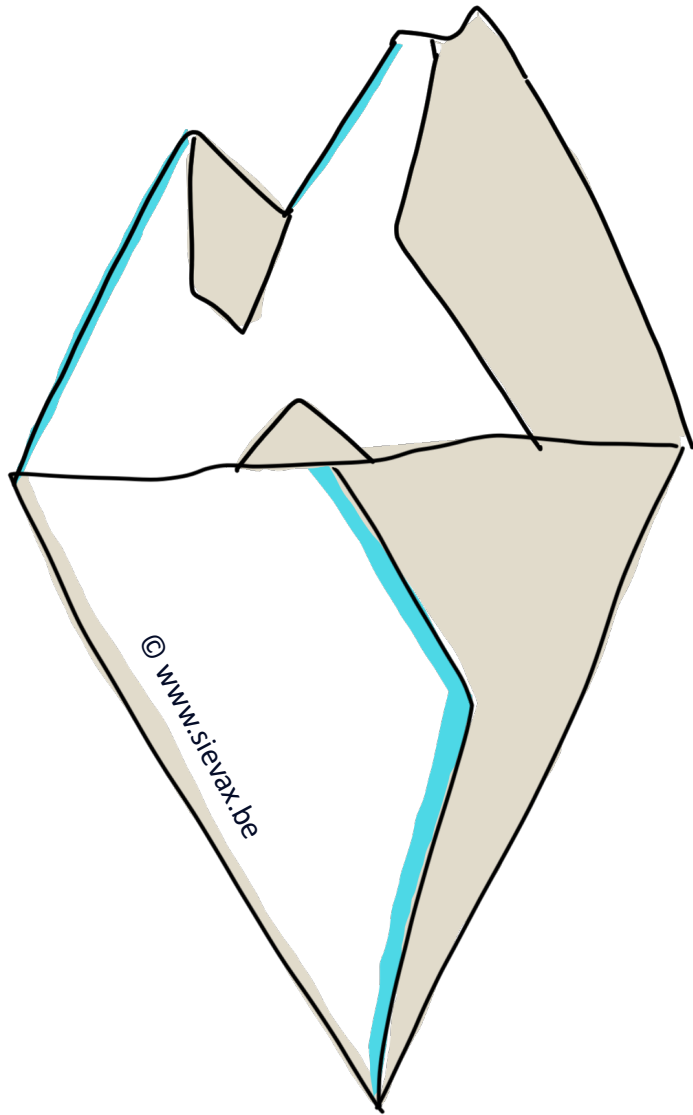

DATA ROADMAP

BUSINESS PRIORITIES

1



2

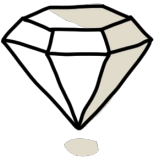

3



DATA ROADMAP

BUSINESS
PRIORITIES

DATA
PRODUCTS

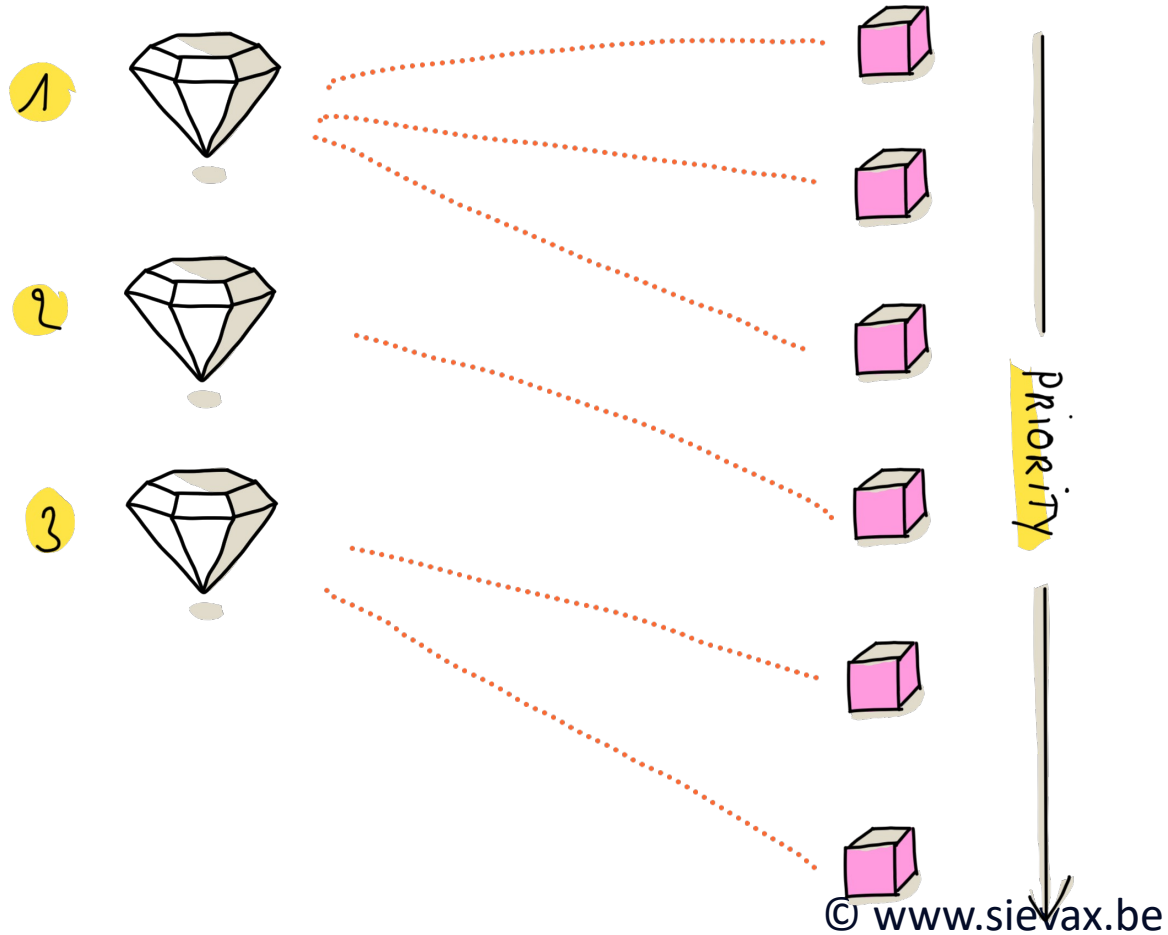

DATA ROADMAP

BUSINESS PRIORITIES

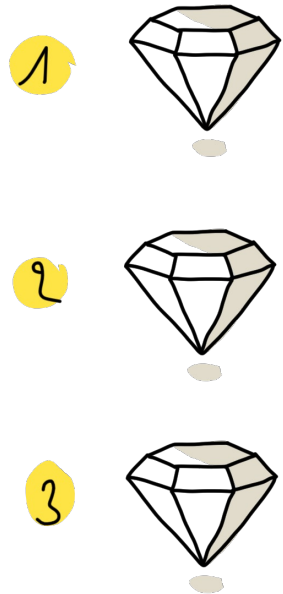

DATA PRODUCTS



DATA GOVERNANCE

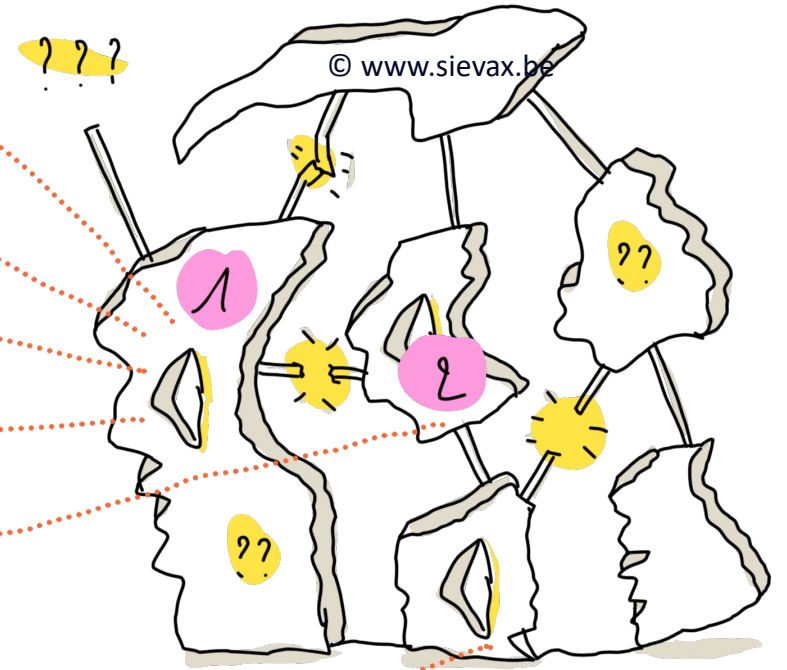

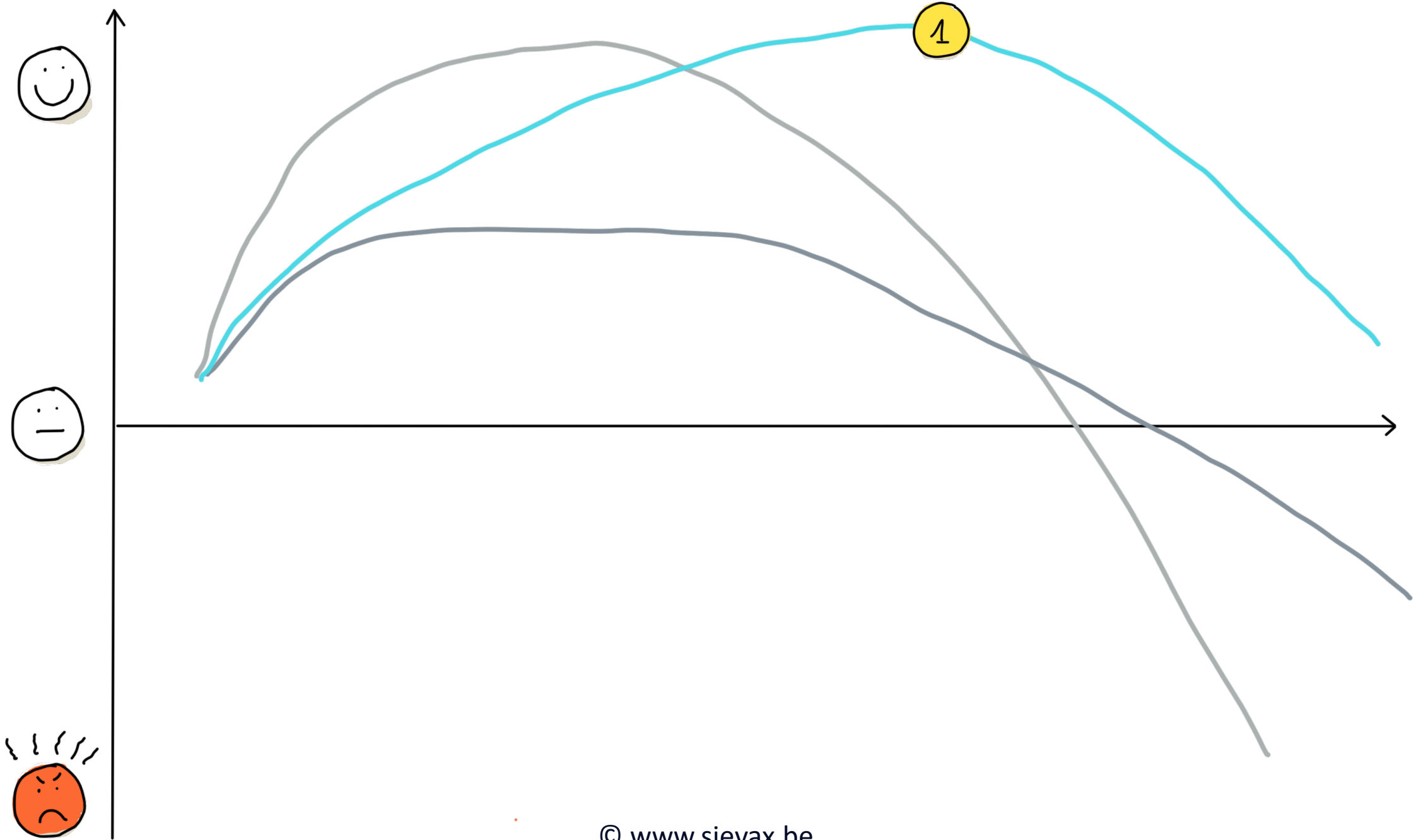

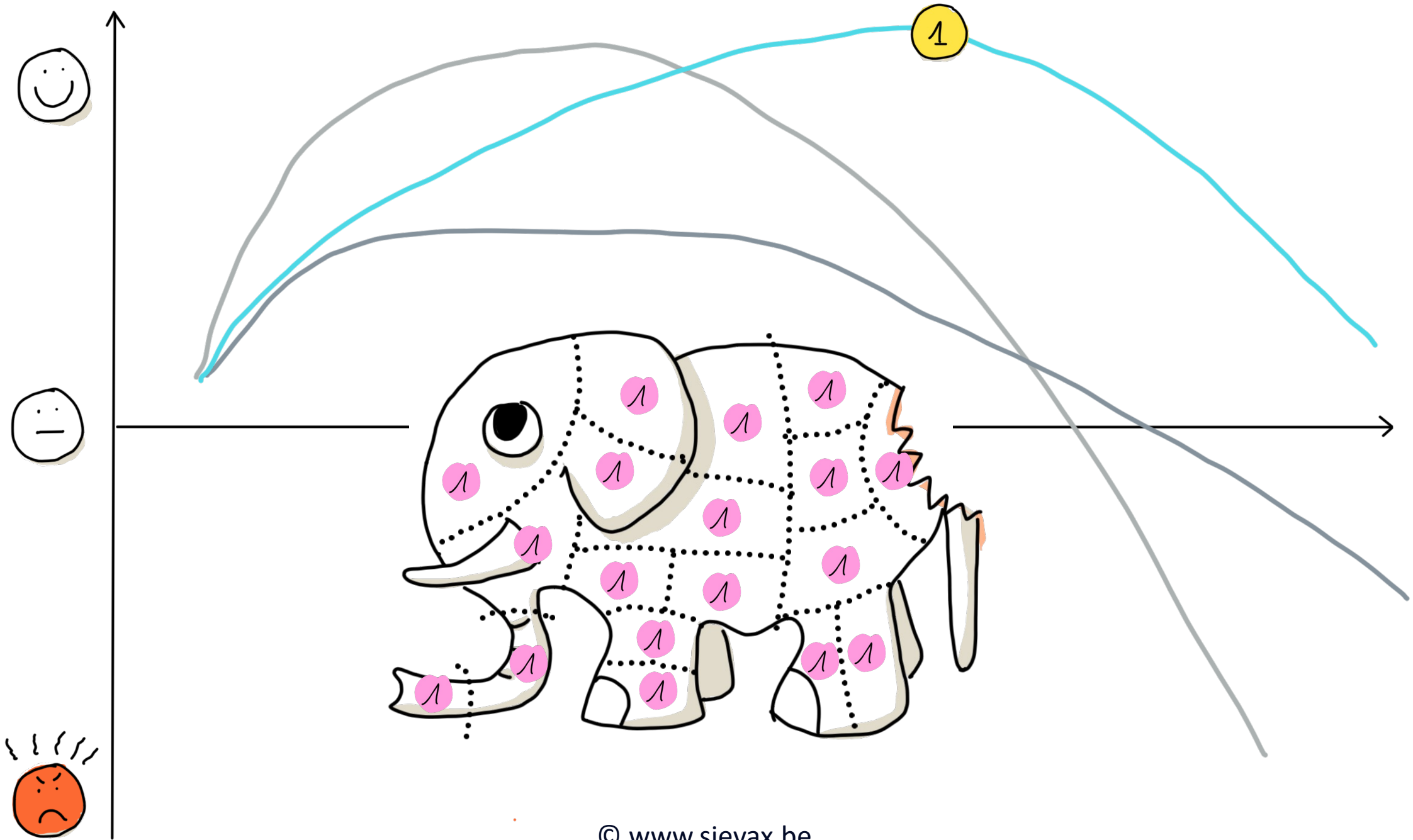

MY JOURNEY TOWARDS VALUE FROM AI

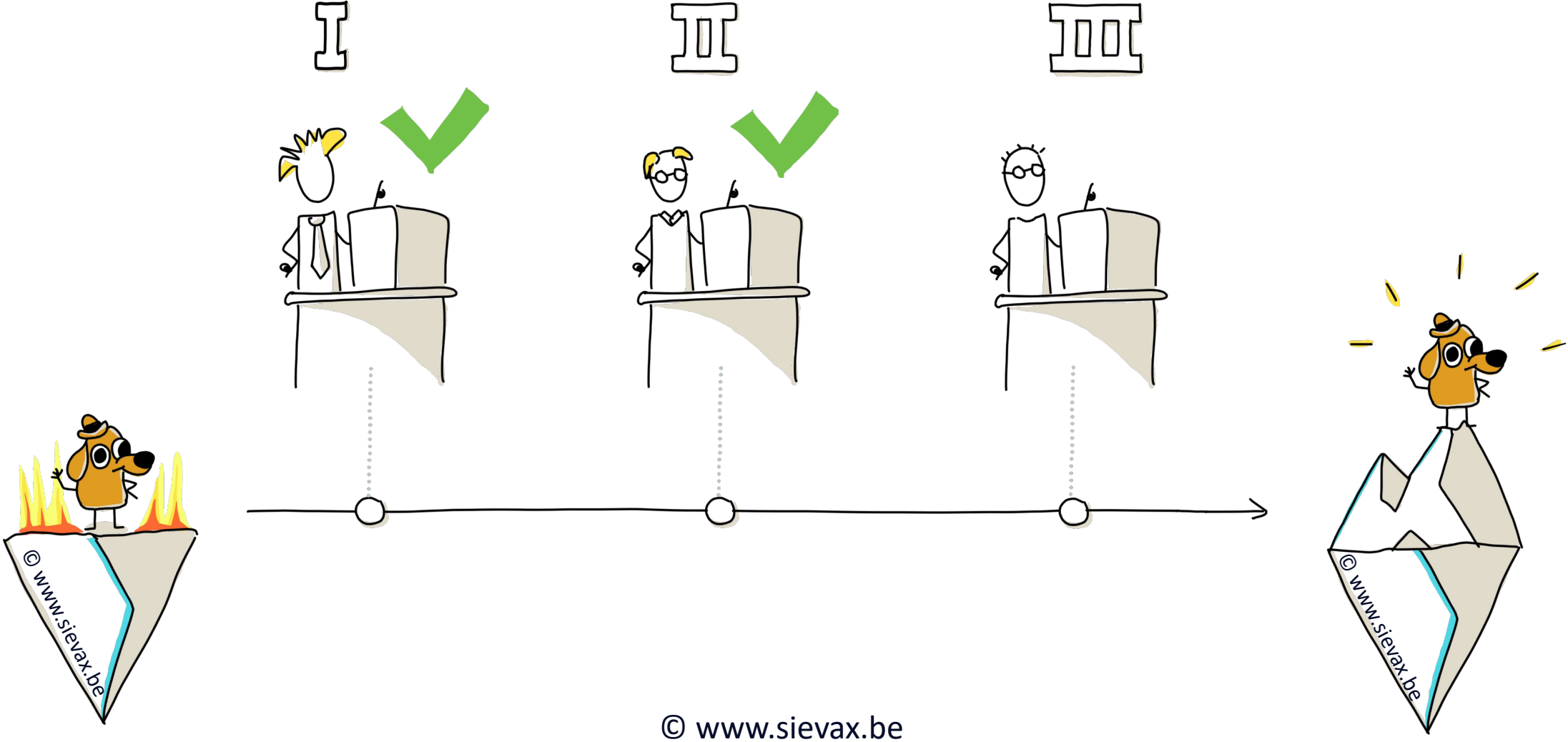

THE DATA STRATEGY APPROACH

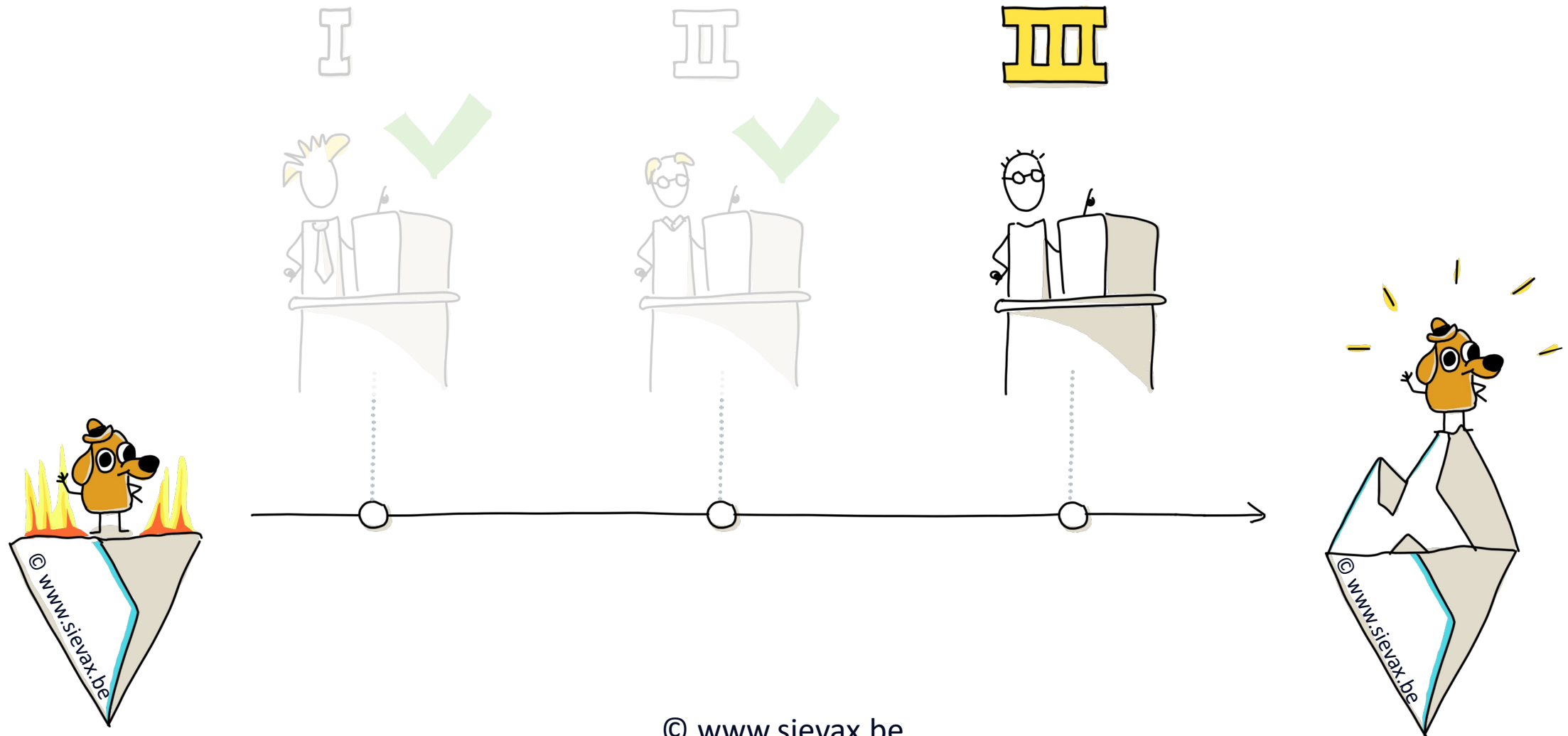

LET'S SUMMARIZE FIRST

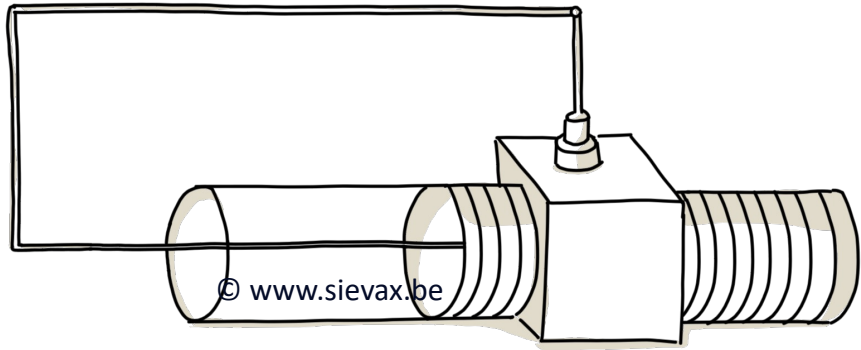

TECHNOLOGY

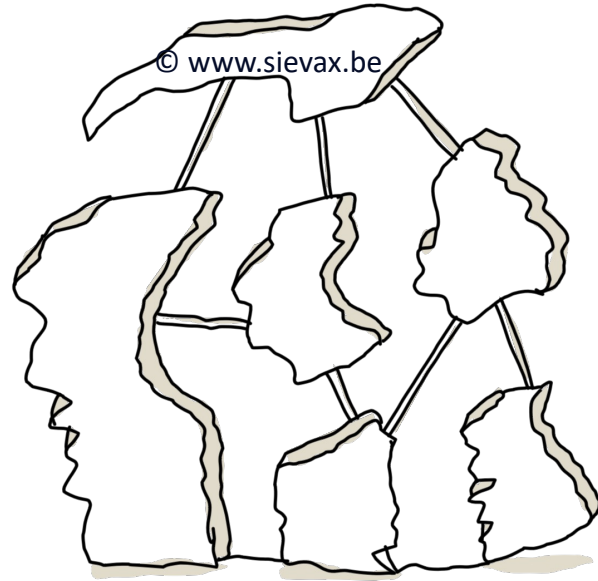

DATA

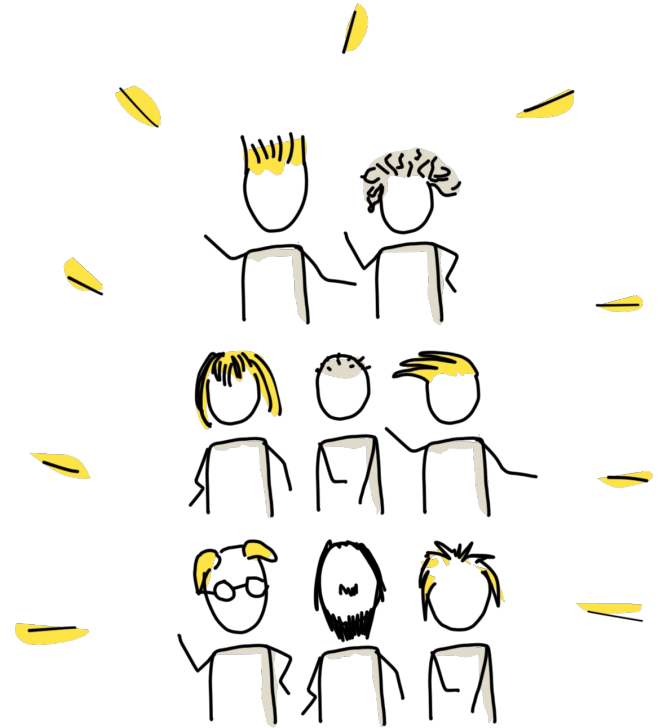

PEOPLE

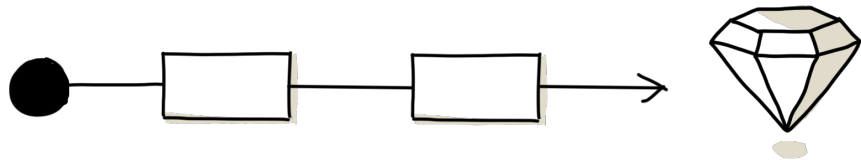

PROCESS

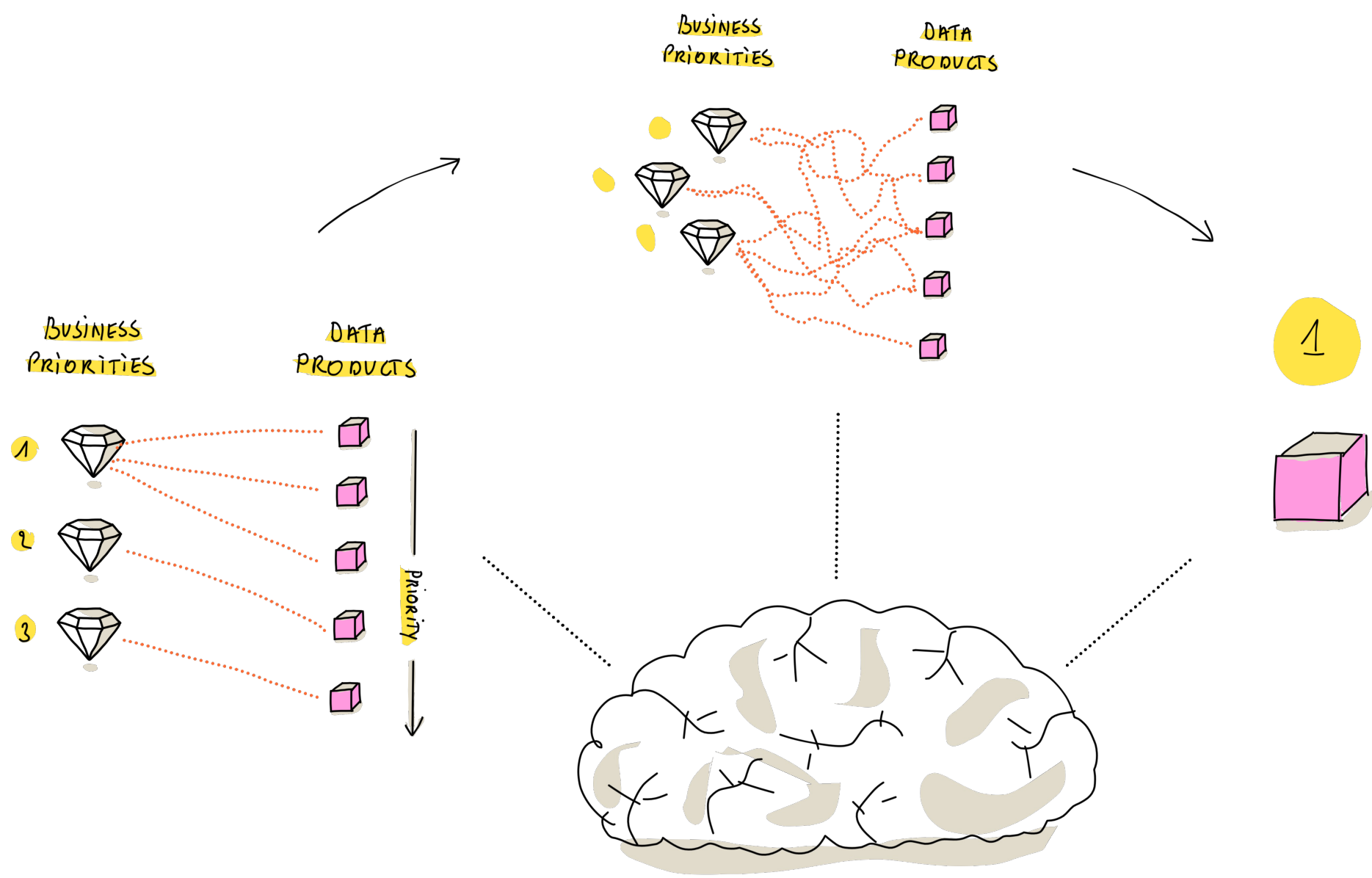

WE NEED MORE THAN A DATA ROADMAP

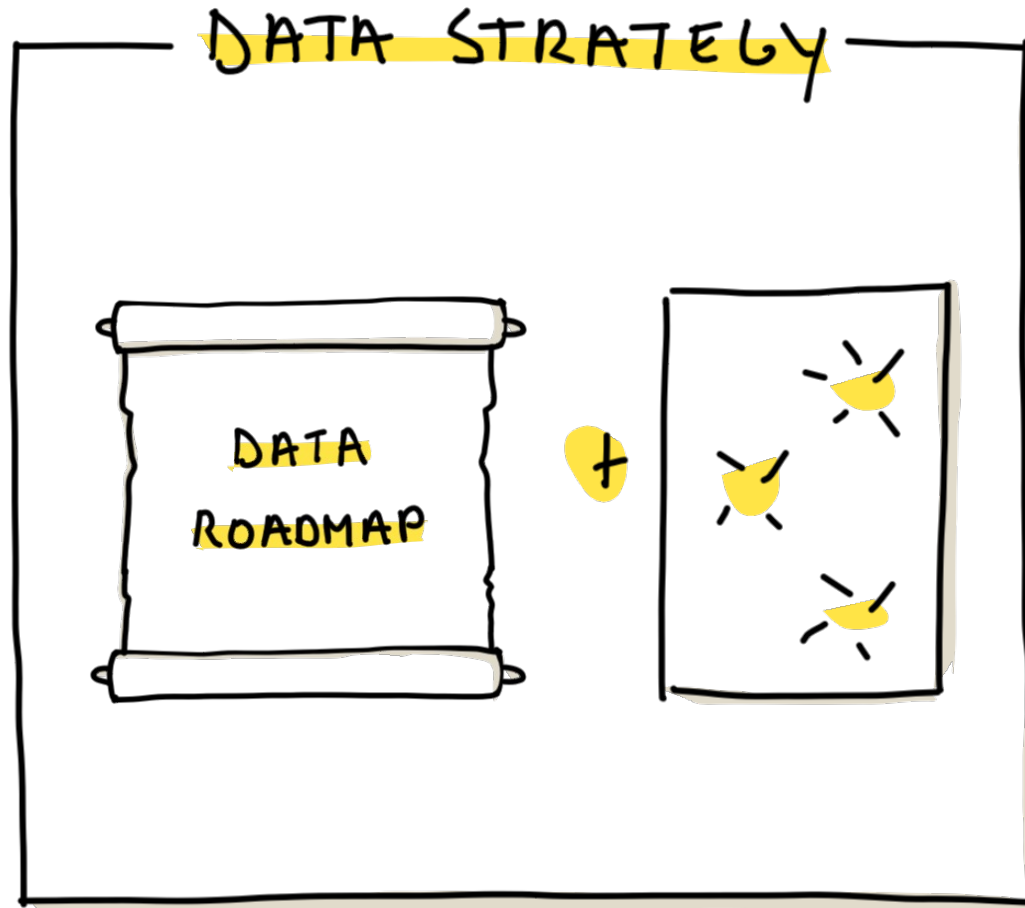

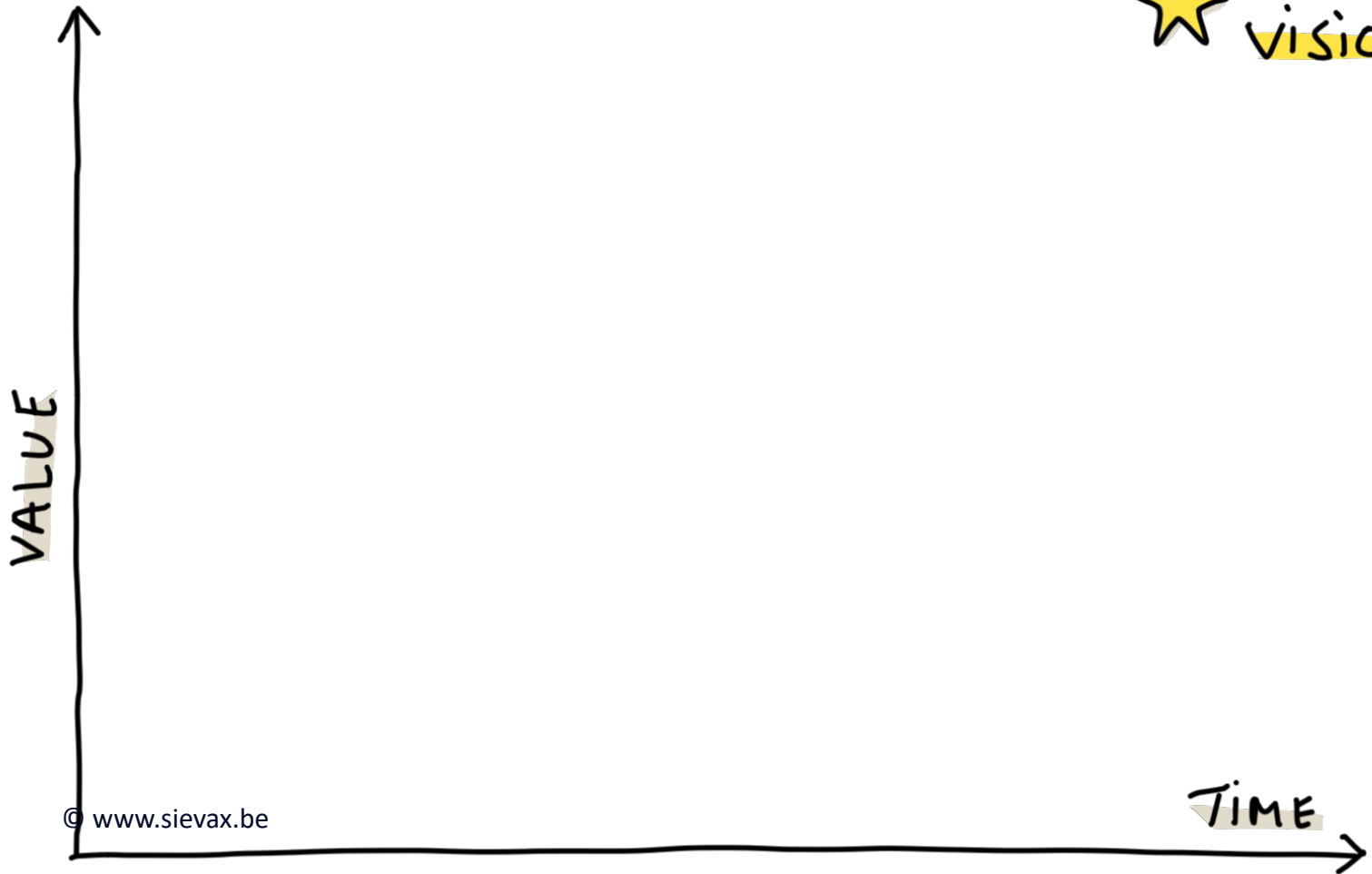

© www.sievax.be

© www.sievax.be

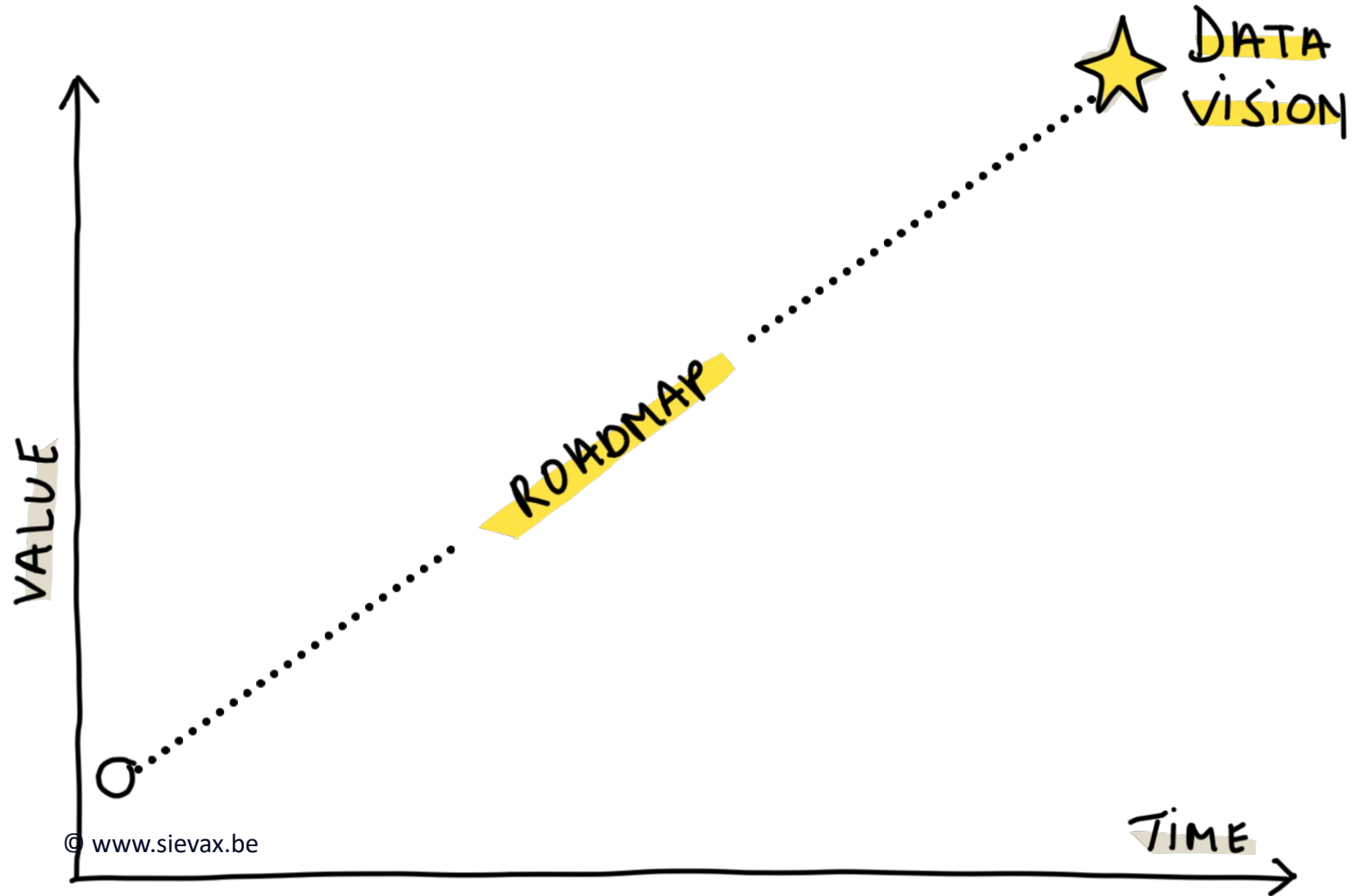

© www.sievax.be

© www.sievax.be

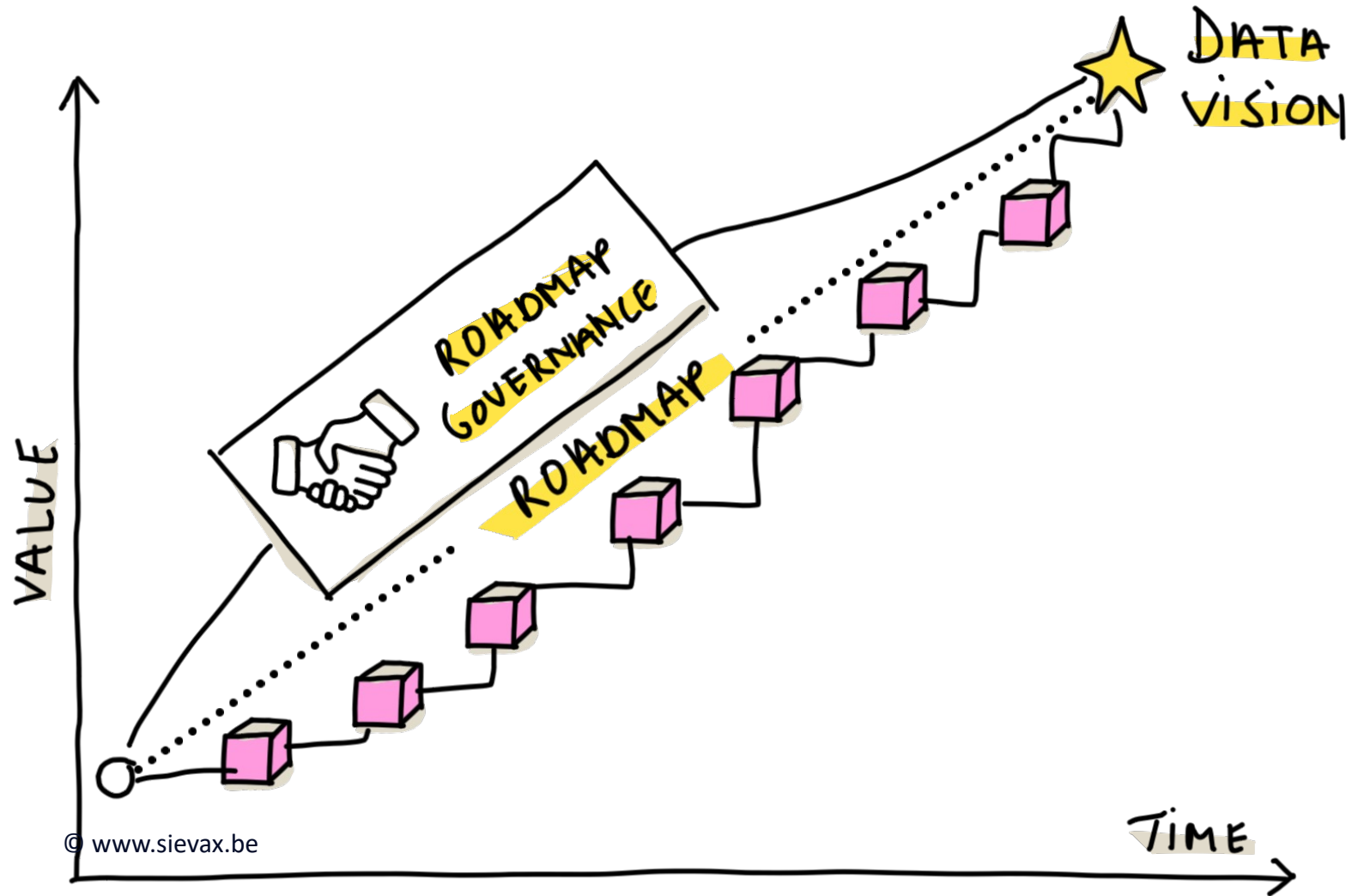

© www.sievax.be

© www.sievax.be

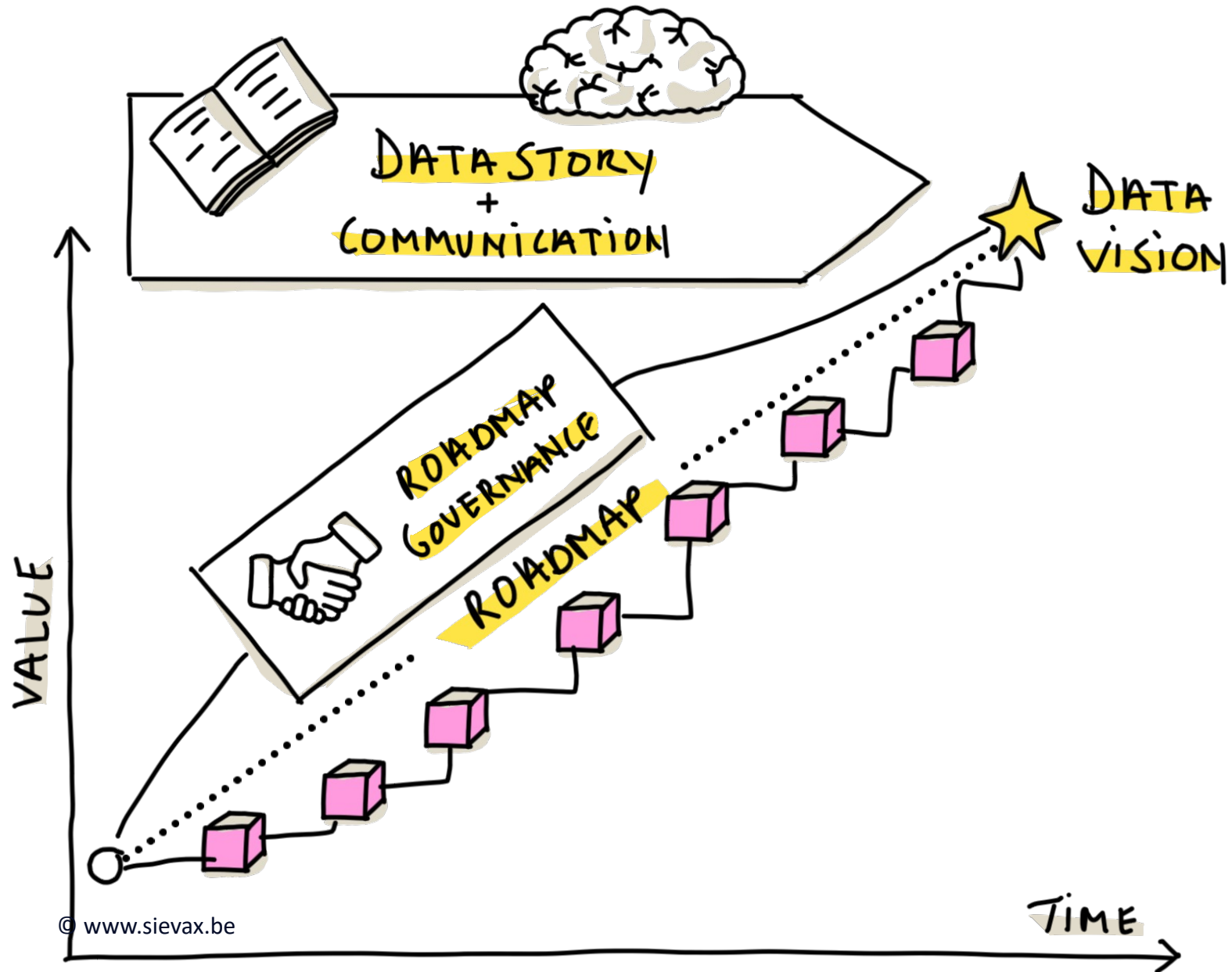

© www.sievax.be

© www.sievax.be

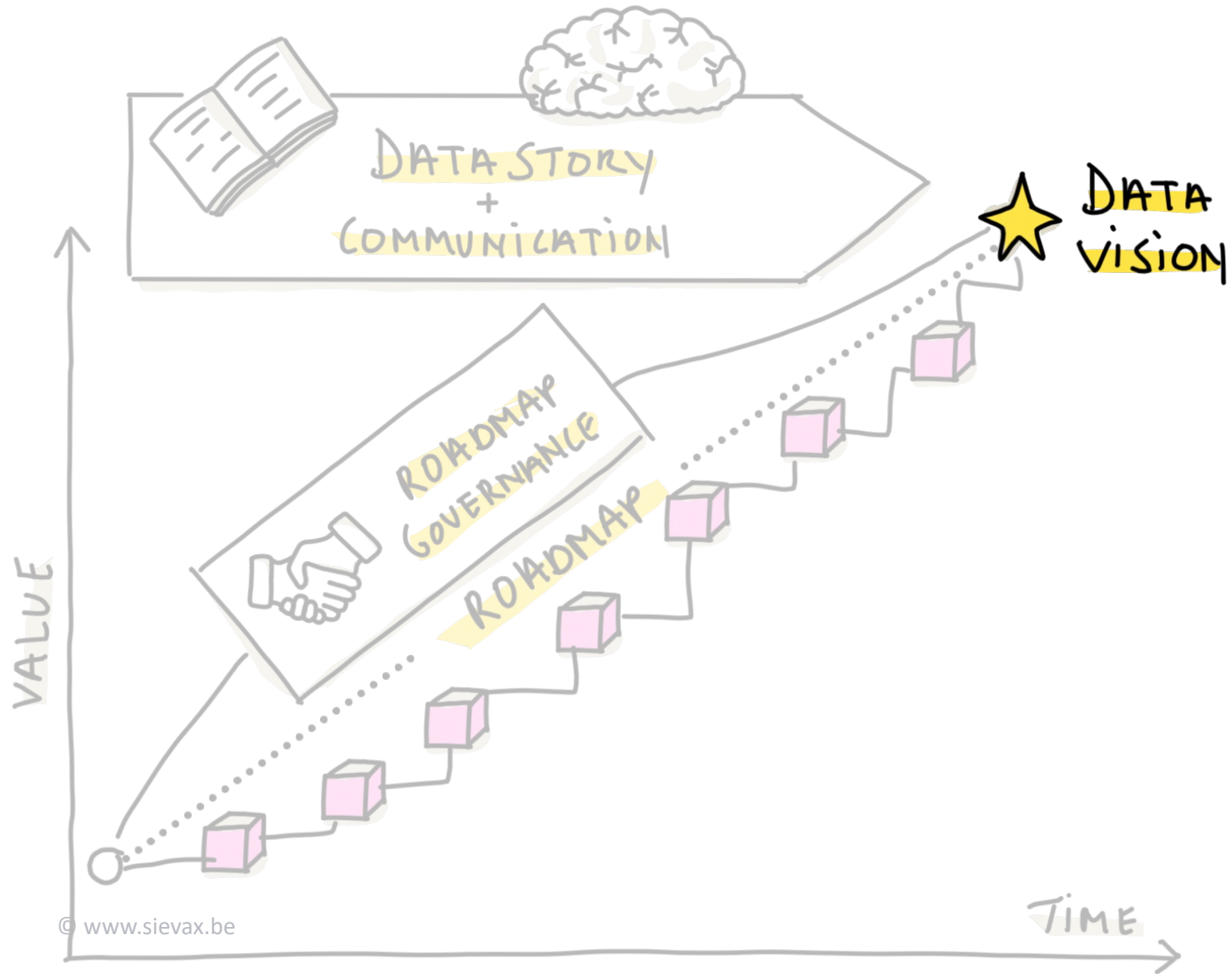

BUSINESS GOALS

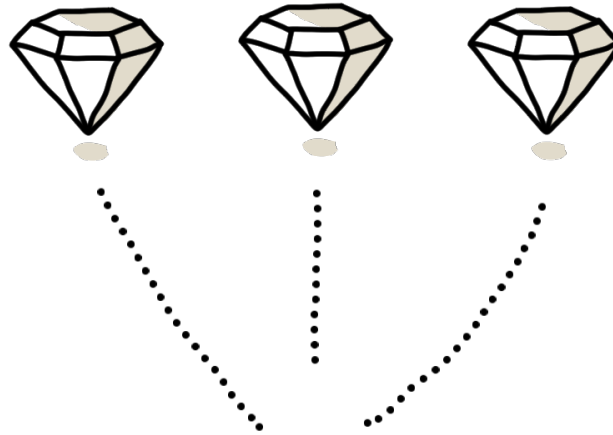

To harness the power of data and AI to drive **smarter, proactive decisions** that create lasting **competitive advantage** and a **future-ready business.**

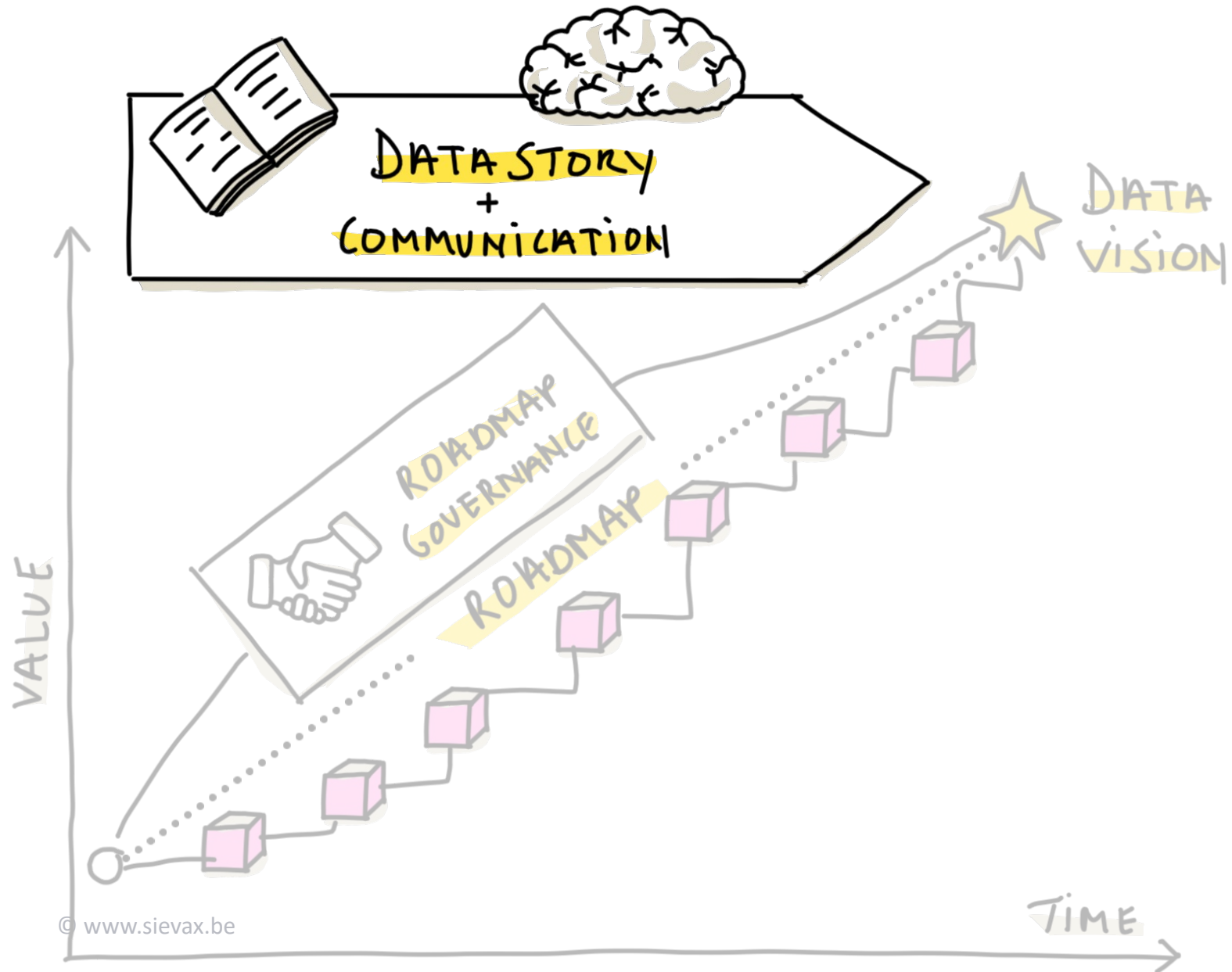

★
DATA VISION

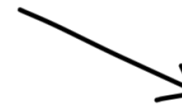
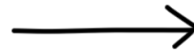
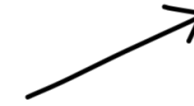
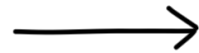

RAW DATA

BUSINESS DATA

GOVERNED DATA

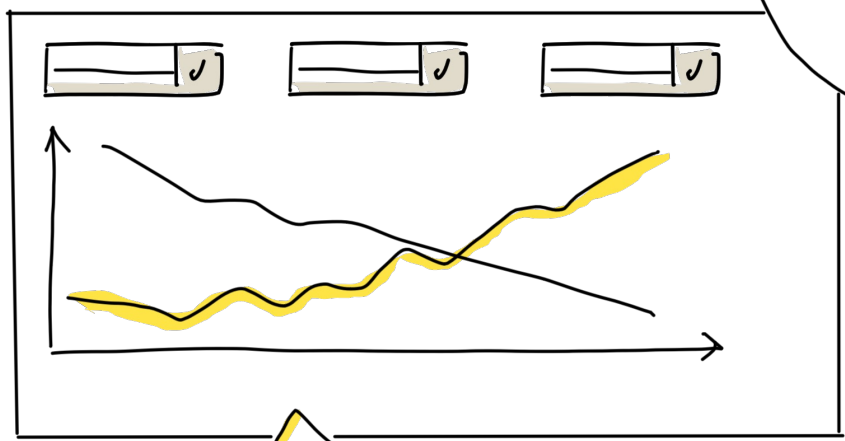
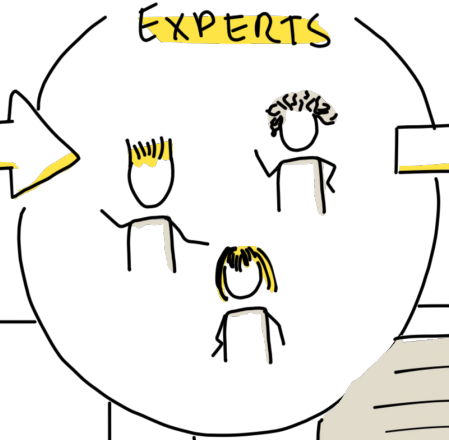
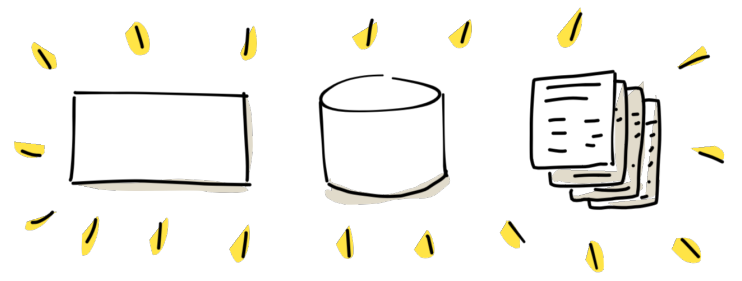
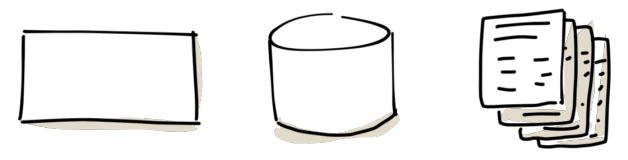

REPORTING

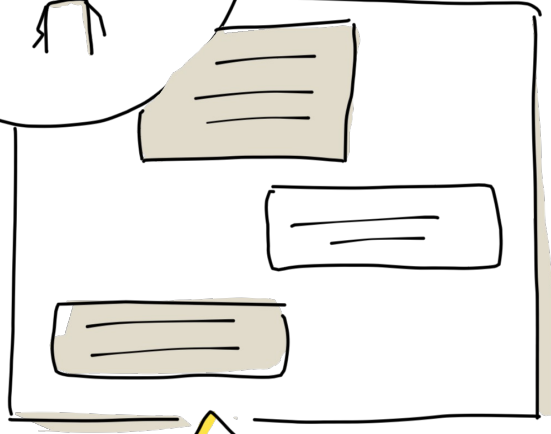

AI ASSISTANT

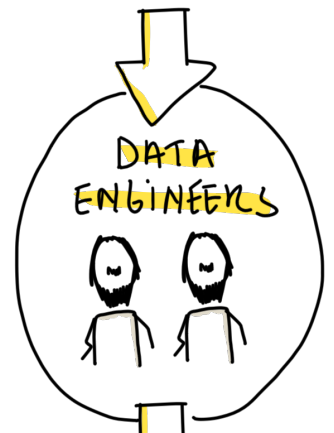

DATA PRODUCT

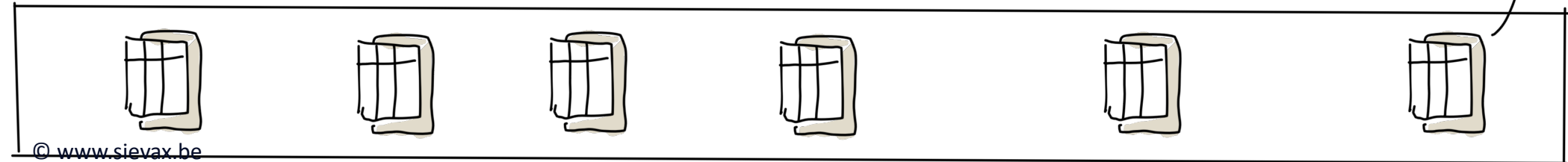

© www.sievax.be

DATA PLATFORM
© www.sievax.be

RAW DATA

BUSINESS DATA

GOVERNED DATA

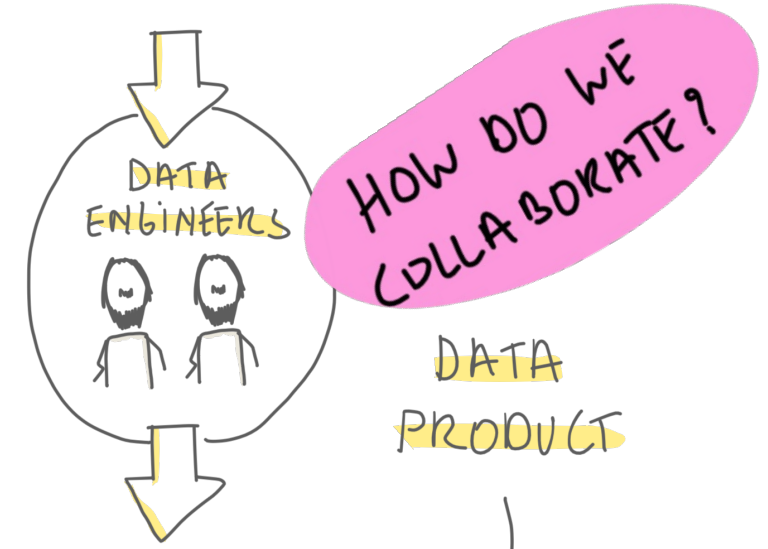
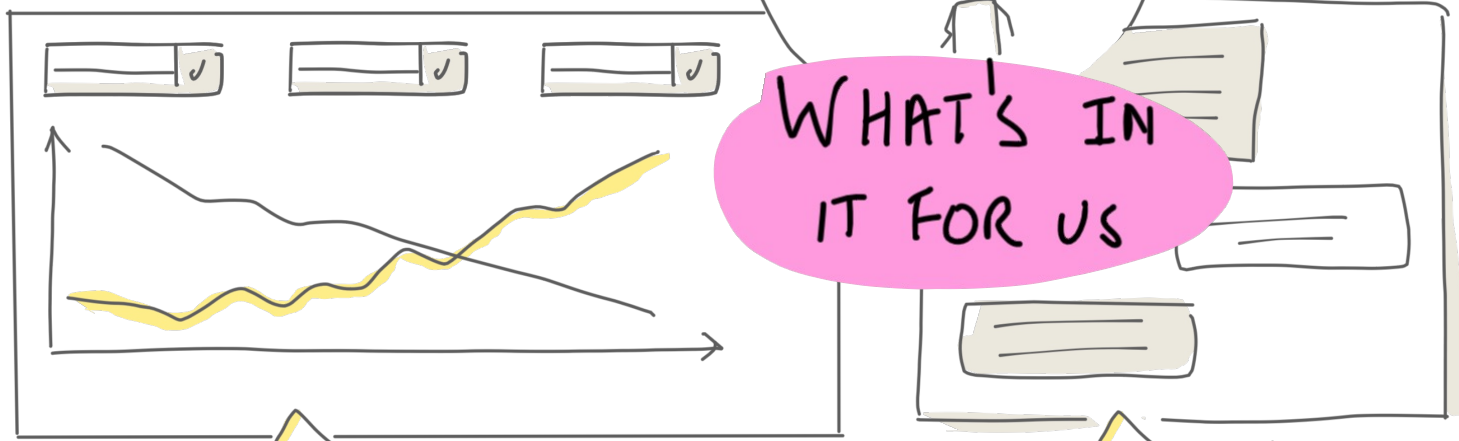
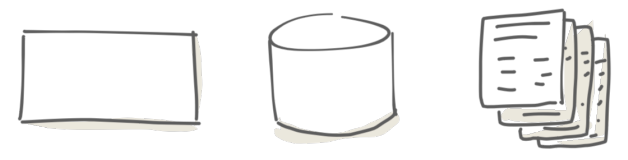

REPORTING



AI ASSISTANT

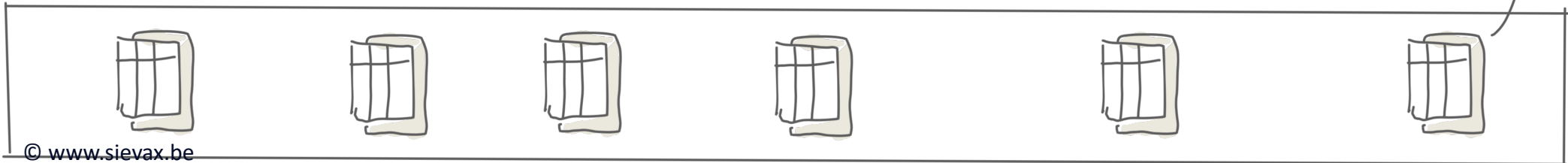

© www.sievax.be

DATA PLATFORM
© www.sievax.be

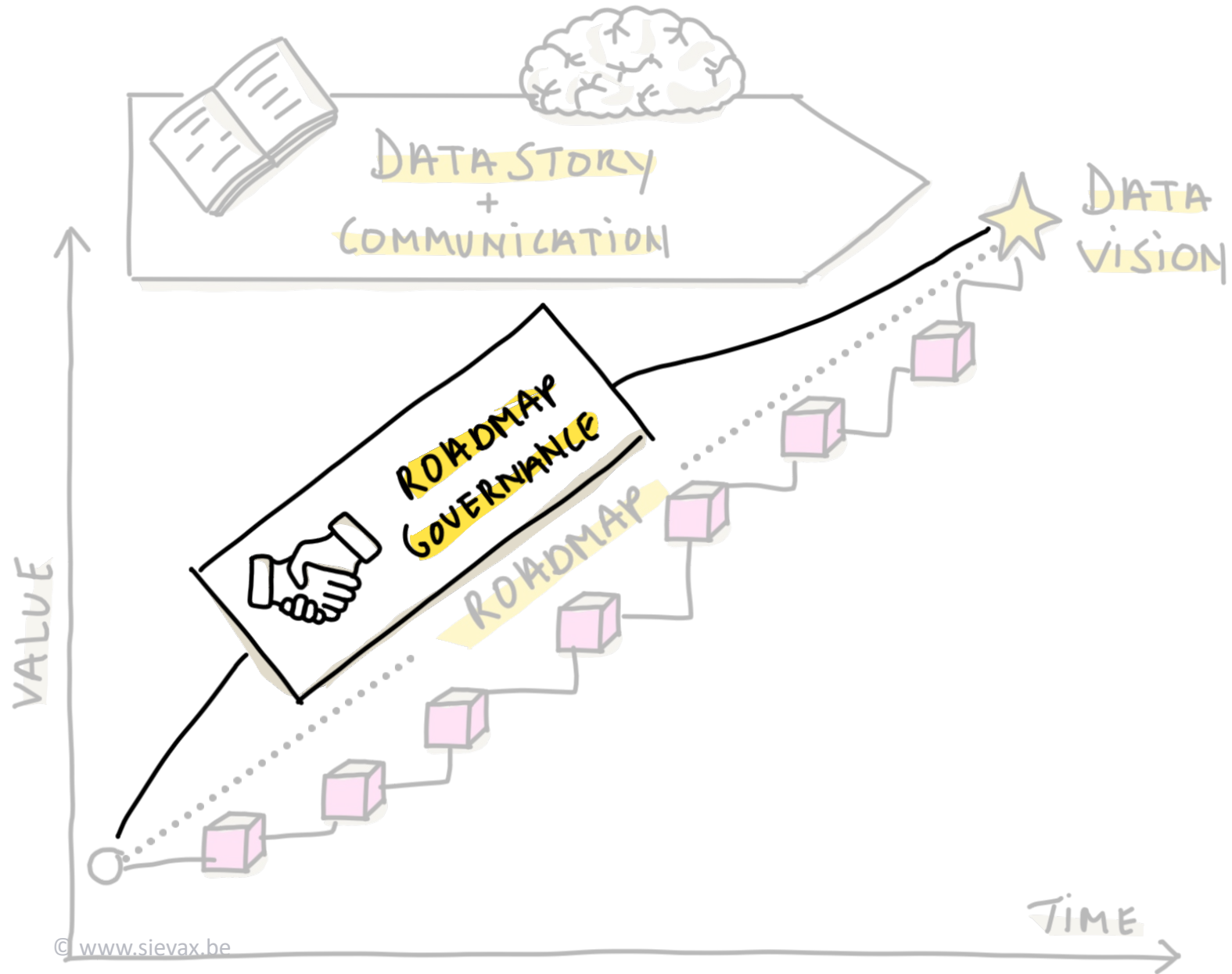

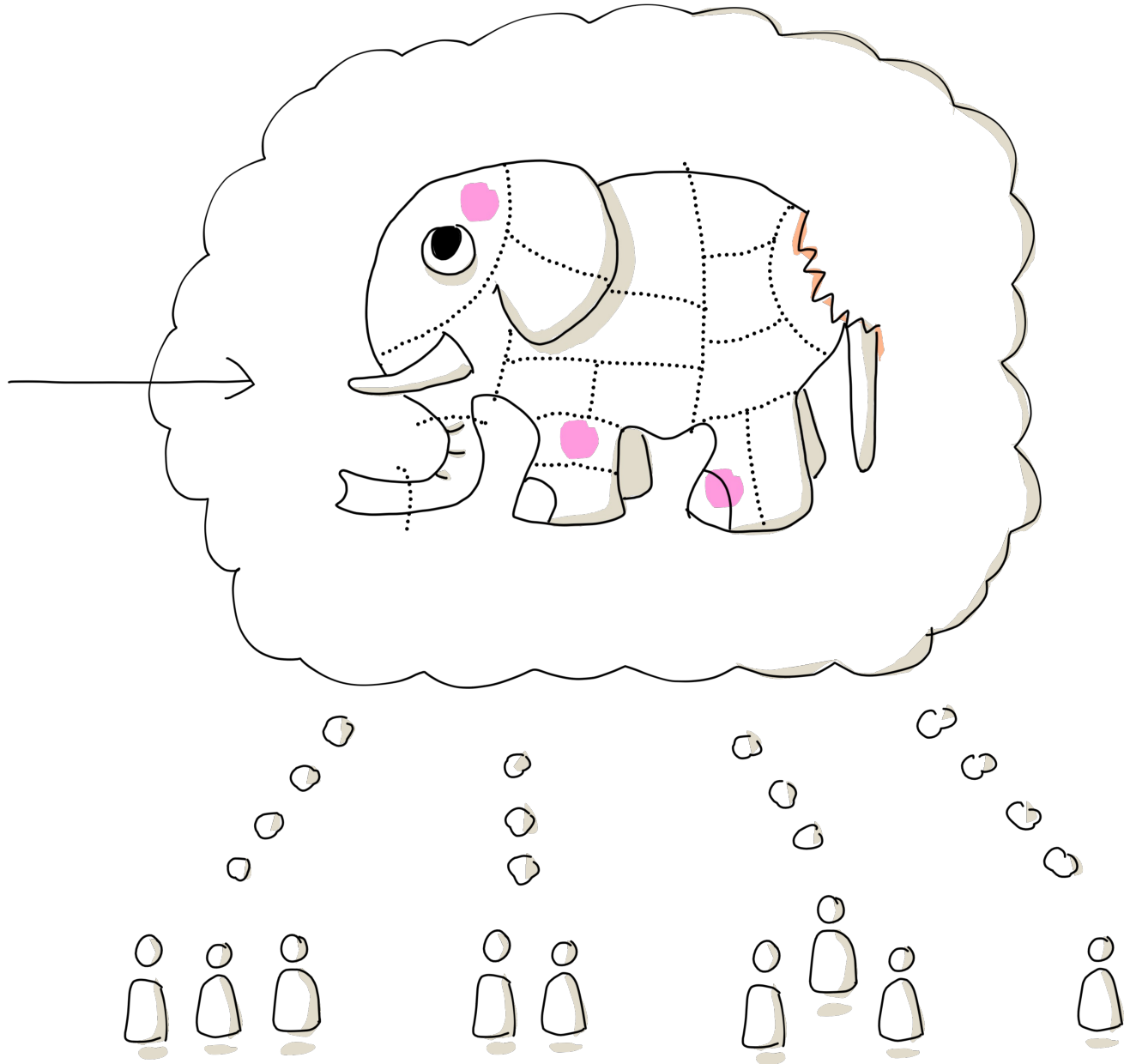
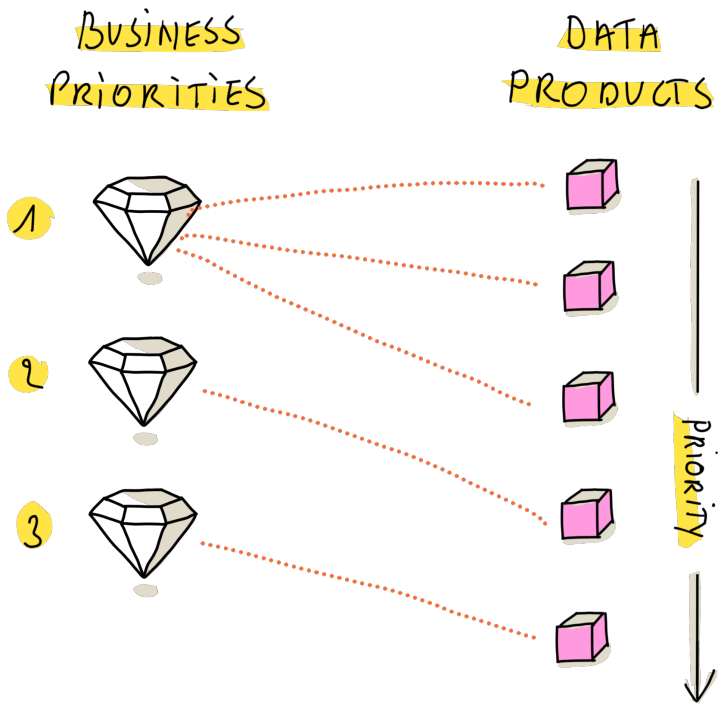

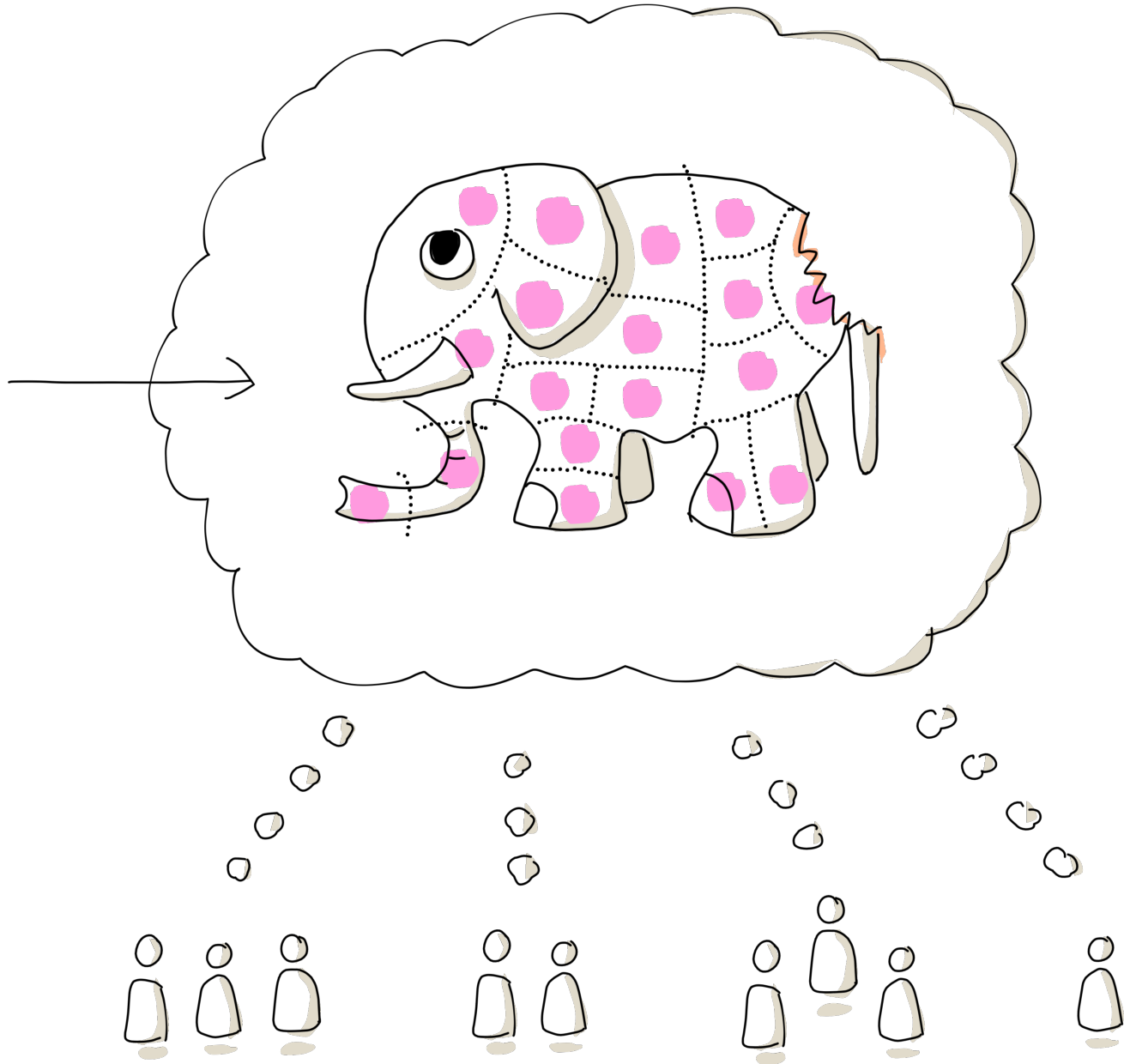
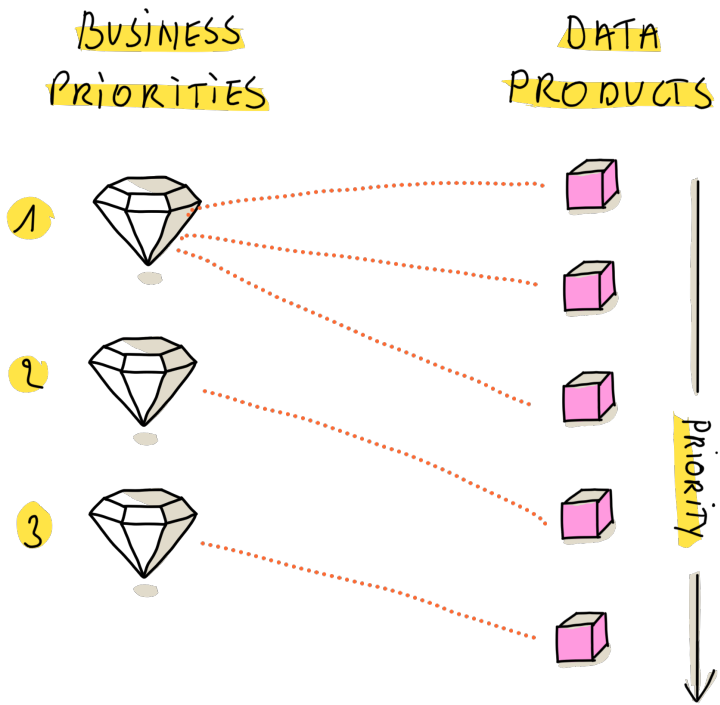

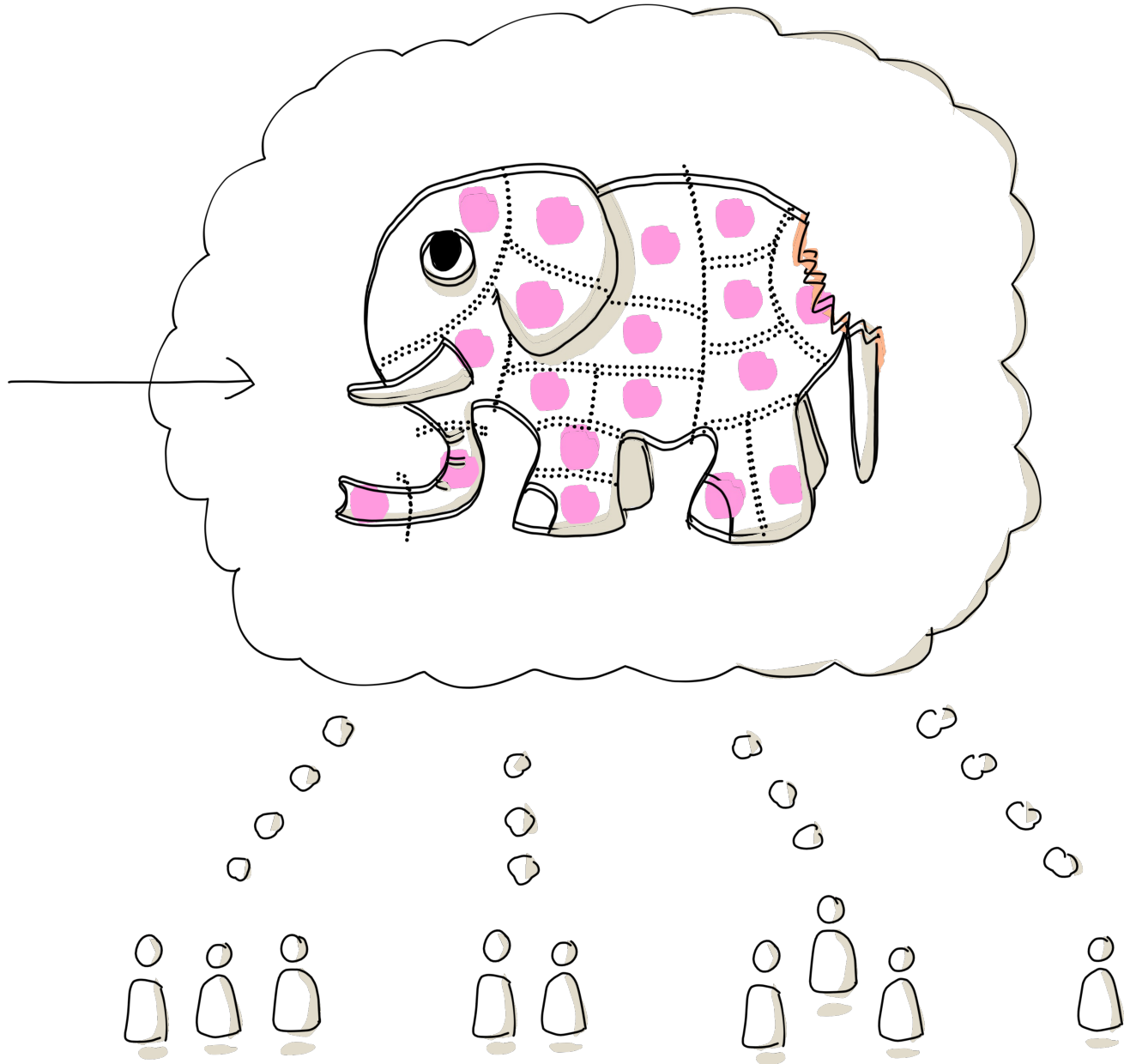
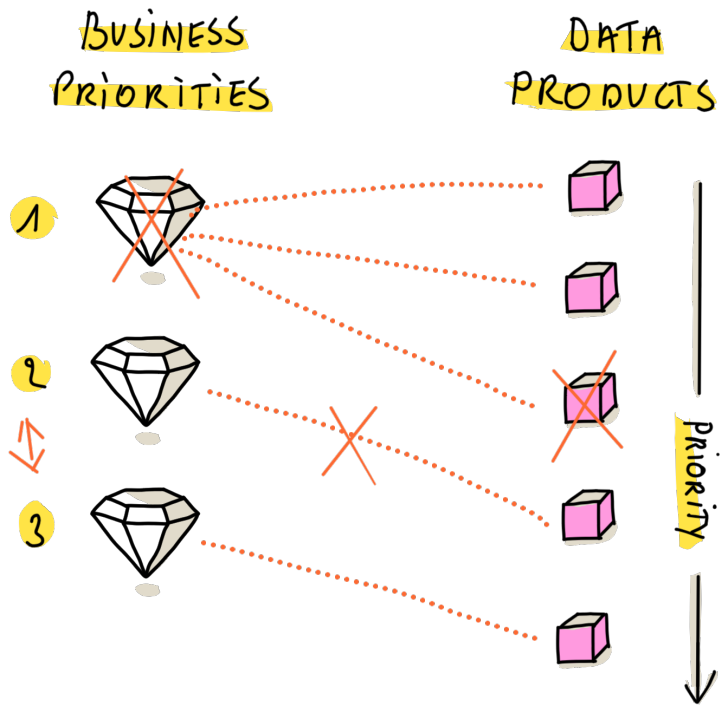

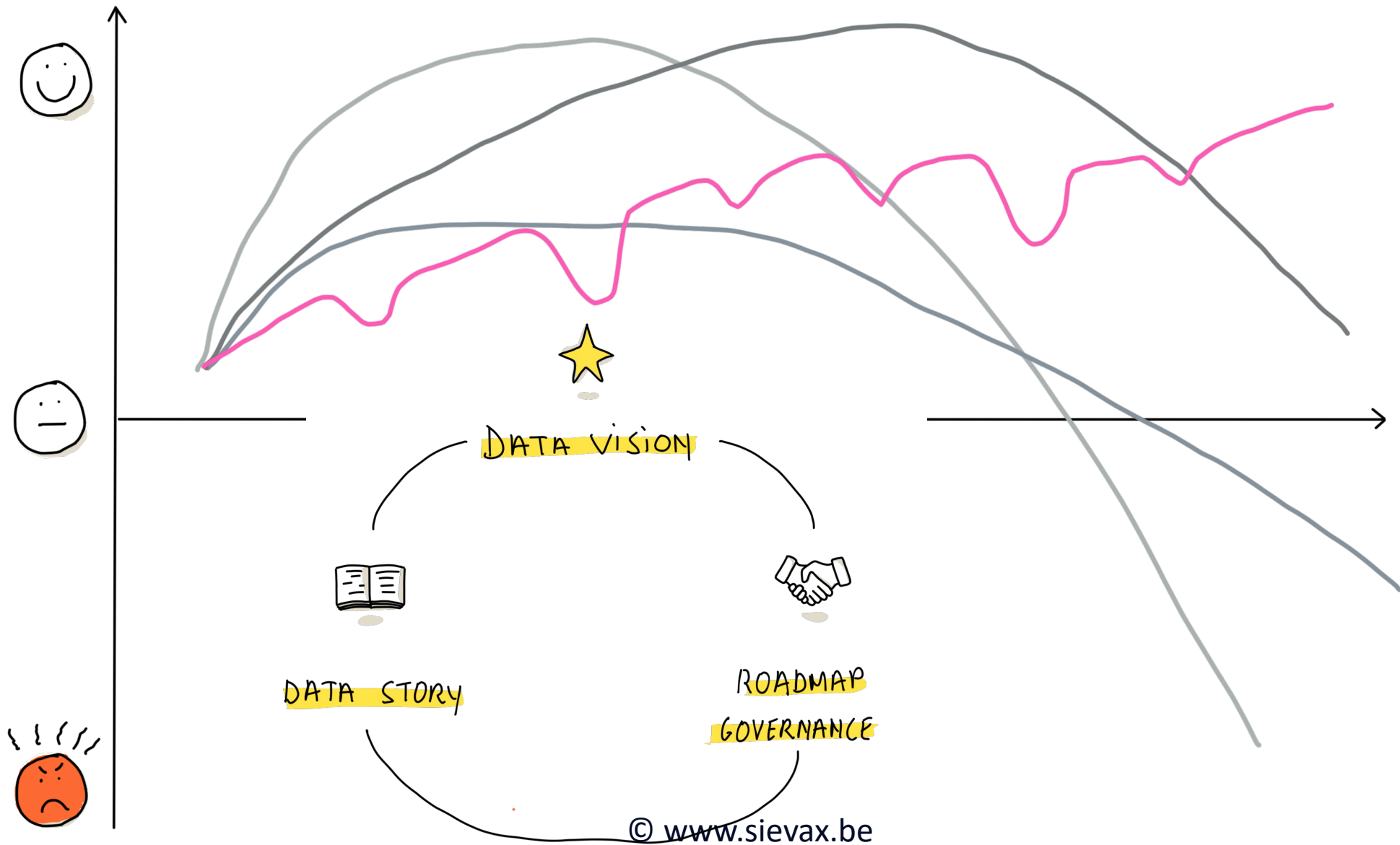

DATA VISION

DATA STORY

ROADMAP
GOVERNANCE

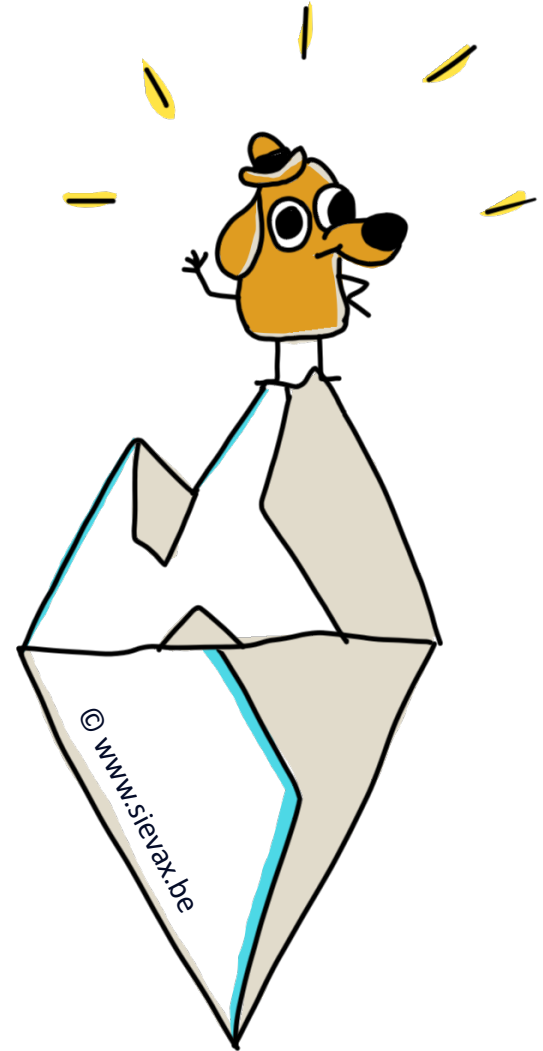

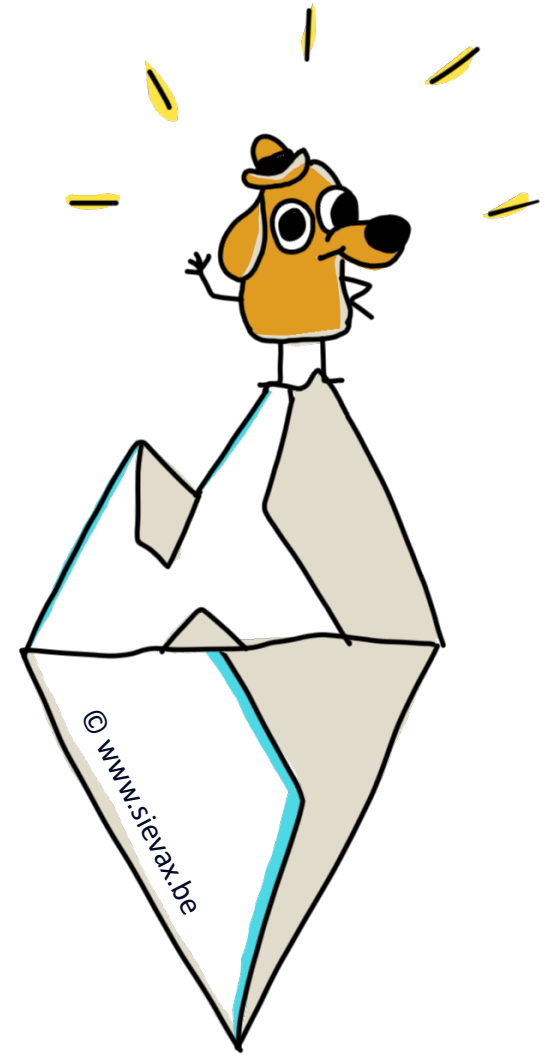

CHANGING DATA CULTURE

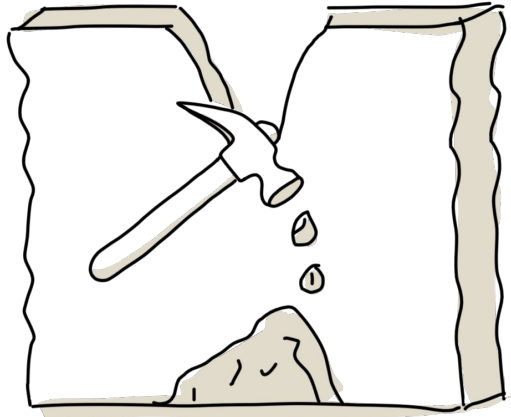

BREAKING SILO'S

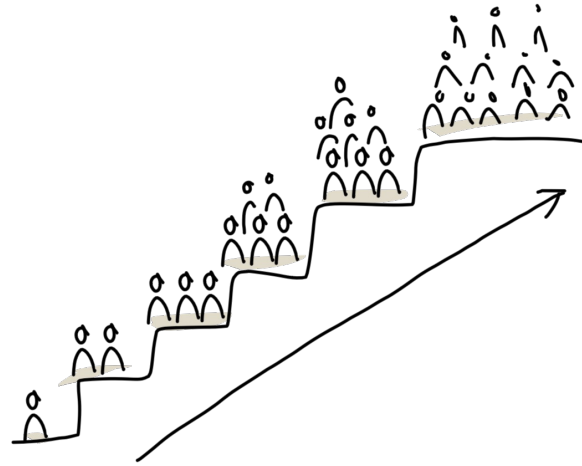

GROW TOGETHER

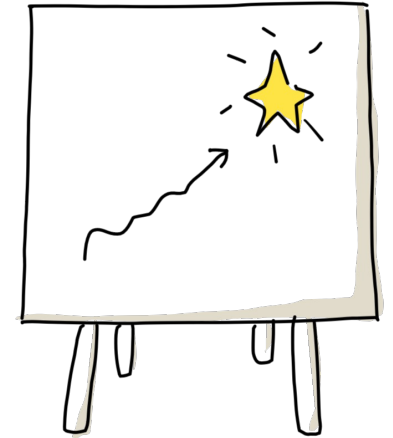

VISUAL THINKING

CHANGING DATA CULTURE

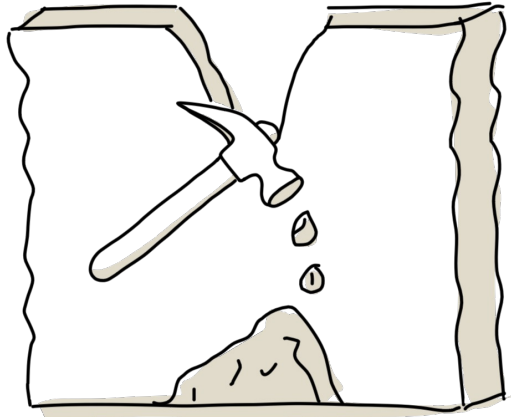

BREAKING SILO'S

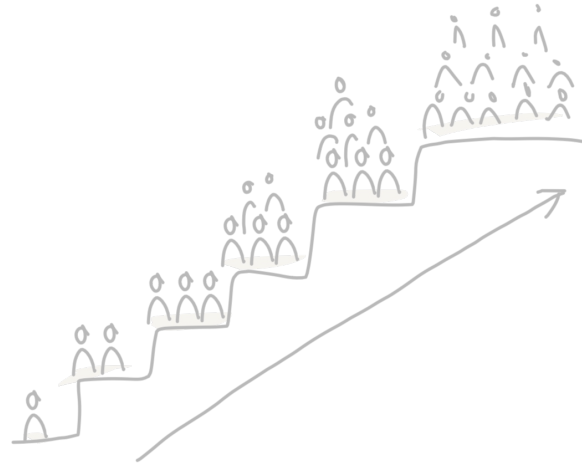

GROW TOGETHER



VISUAL THINKING

DATA PRODUCER
STRATEGY

DATA CONSUMER
STRATEGY

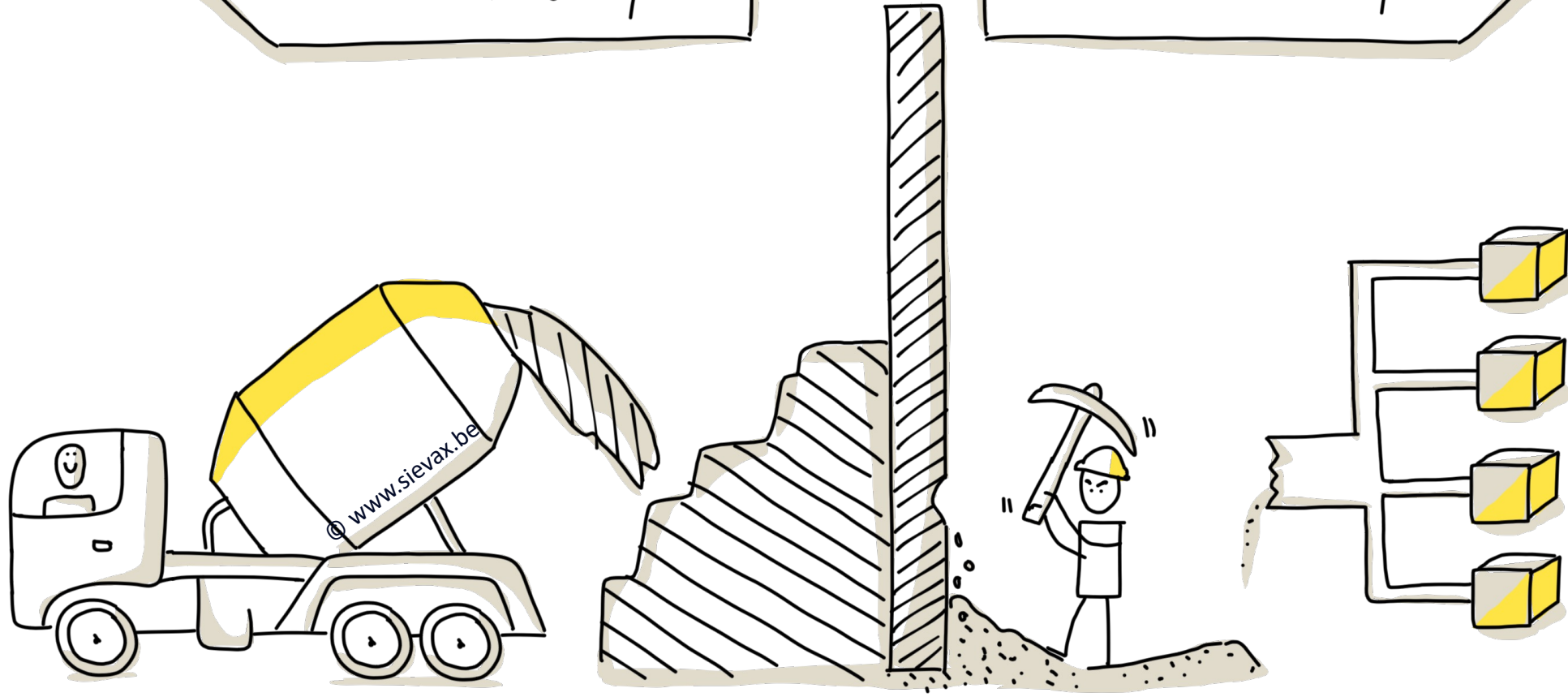

THE
BEST CRM

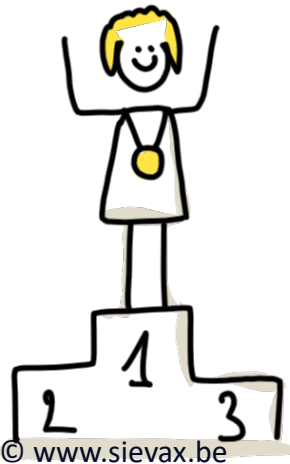

© www.sievax.be

THE
FASTEST ETL



© www.sievax.be

THE BEST
DATA MODEL



THE LONGEST TIME TO MARKET

THE
BEST CRM

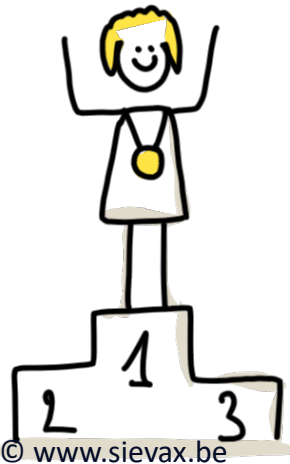

© www.sievax.be

THE
FASTEST ETL



© www.sievax.be

THE BEST
DATA MODEL



CHANGING DATA CULTURE

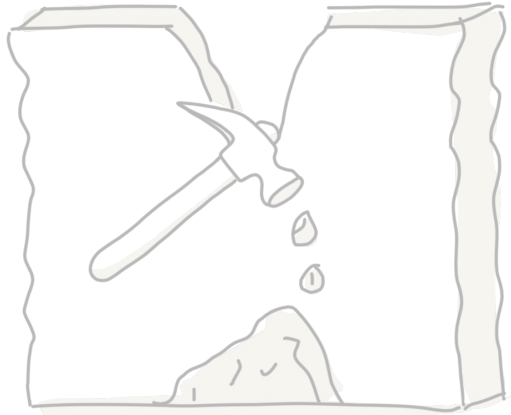

BREAKING SILO'S

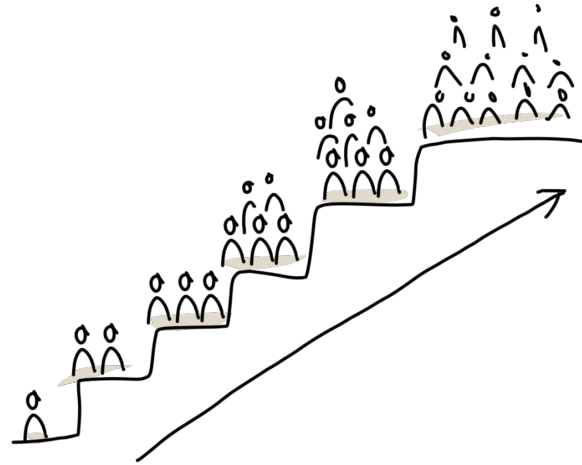

GROW TOGETHER



VISUAL THINKING

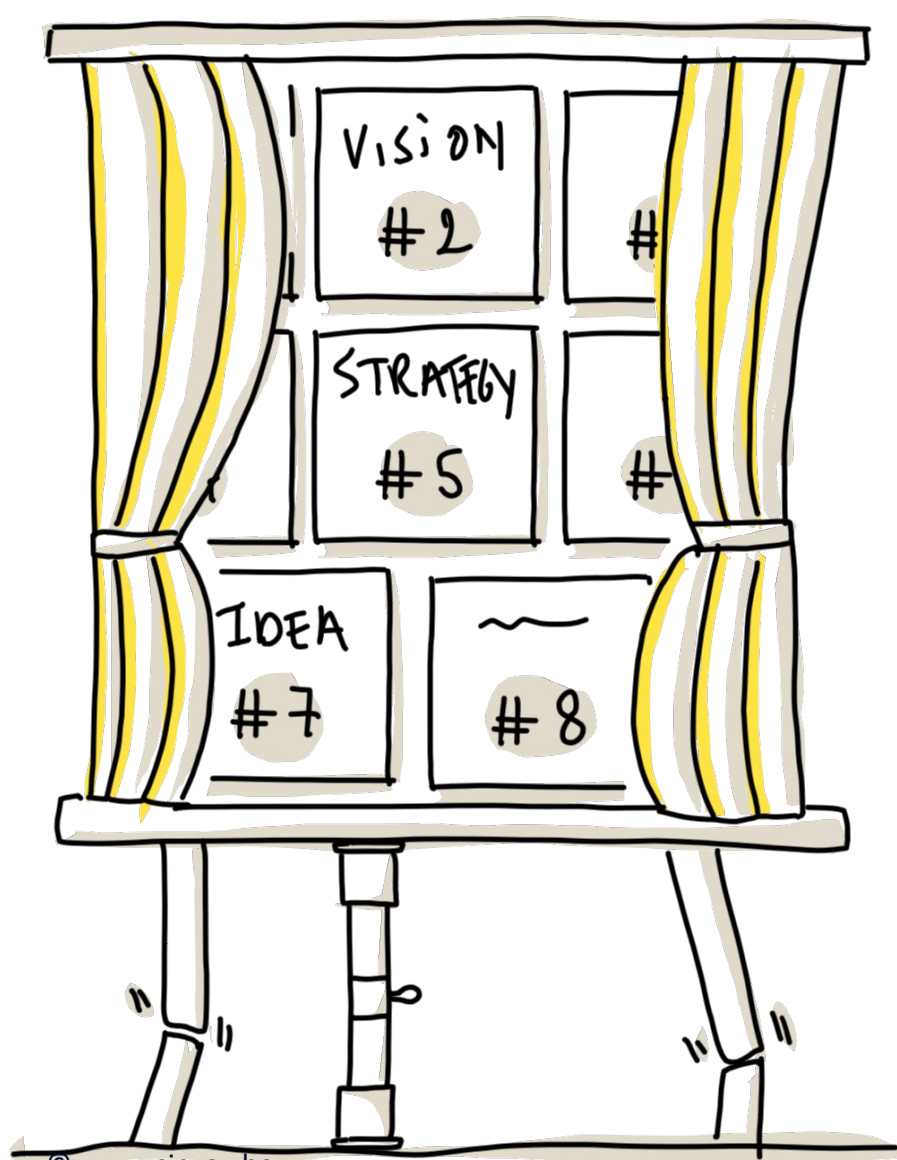

© www.sievax.be



SLIDES

DATA & AI
FOUNDATIONS

© www.sievax.be

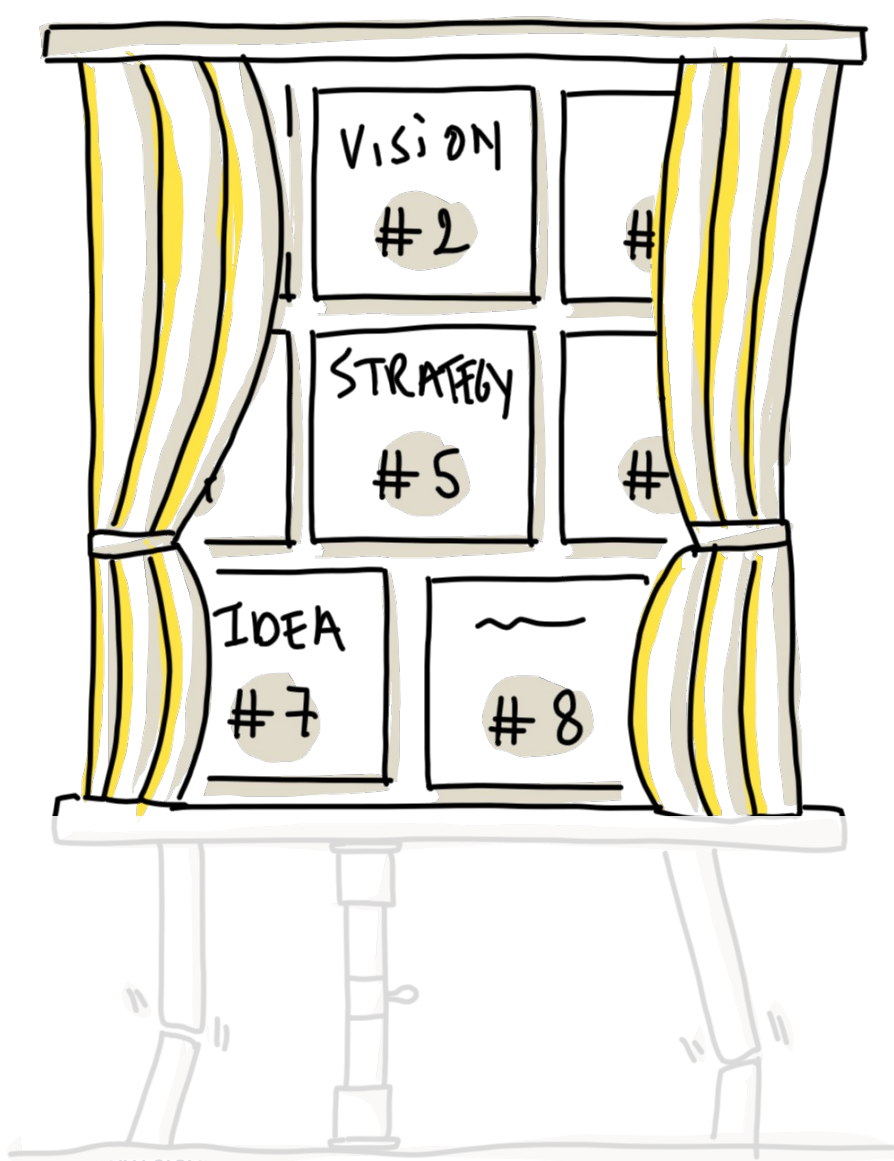

© www.sievax.be

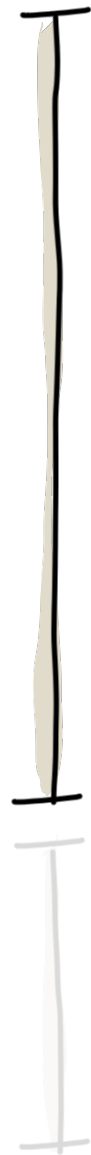

SLIDES

DATA & AI
FOUNDATIONS

© www.sievax.be

THINK BIG

THINK SMALL

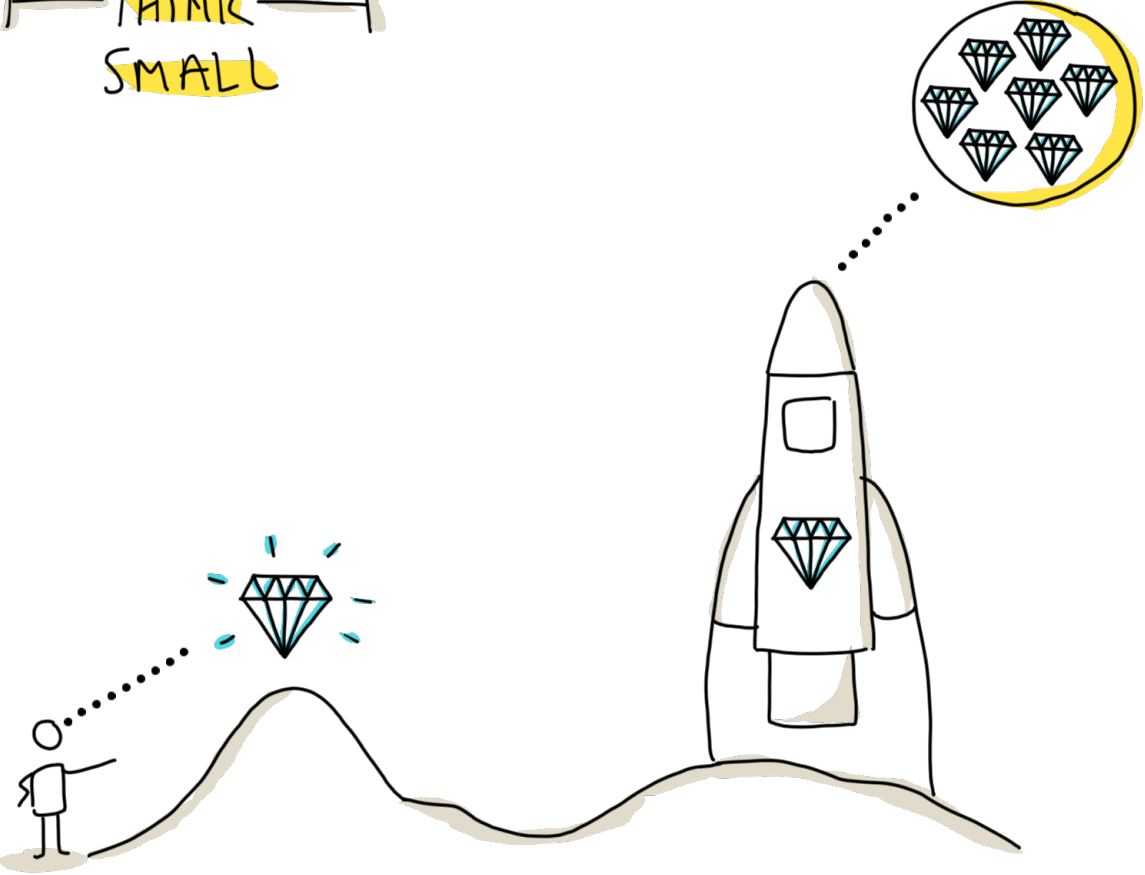

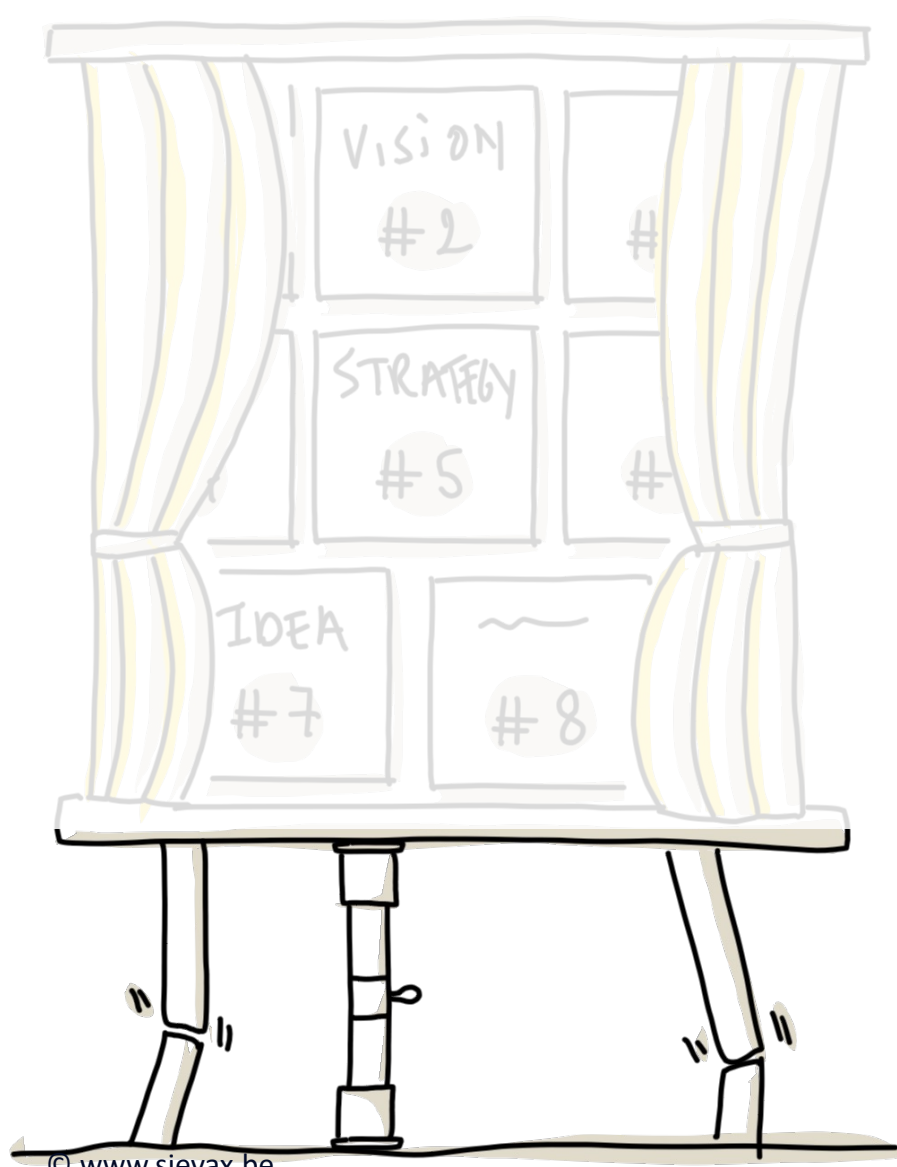

SLIDES

DATA & AI
FOUNDATIONS

Buy:

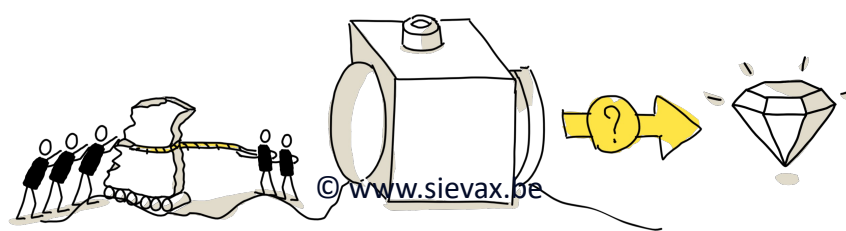
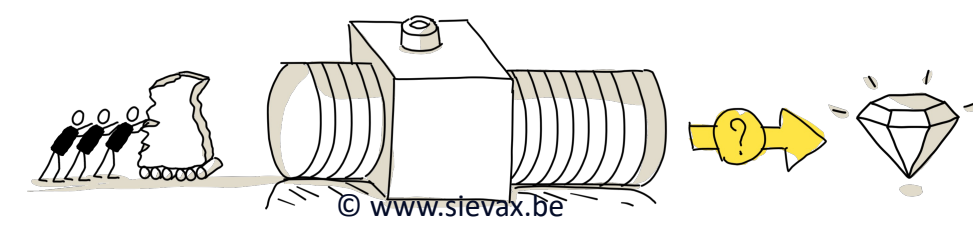
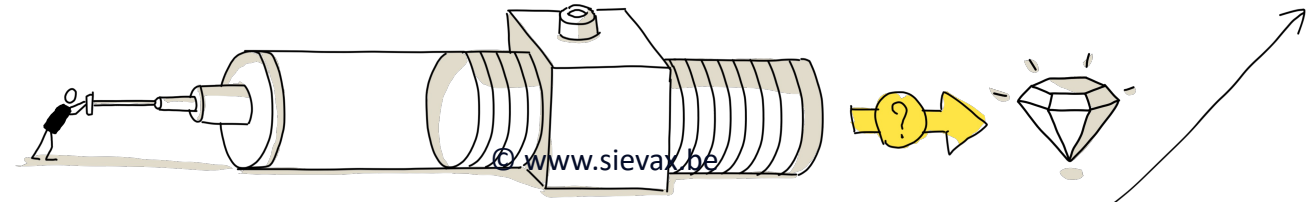
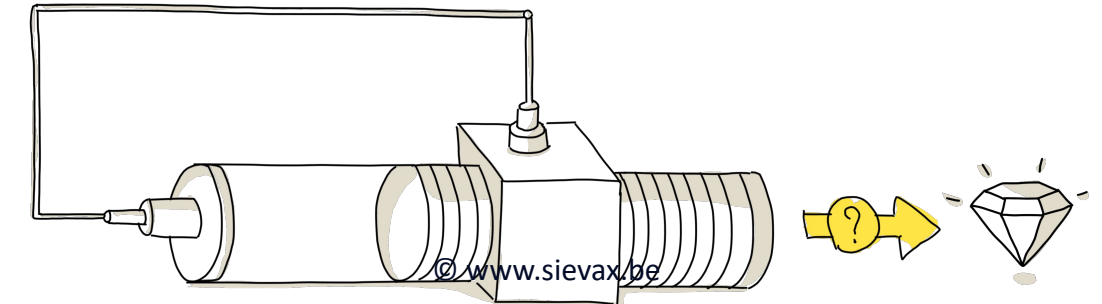

BUILD

CHANGING DATA CULTURE

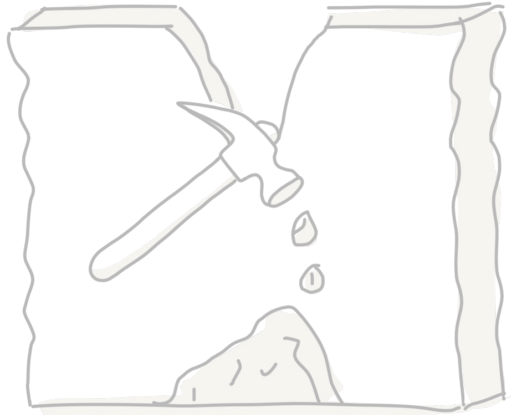

BREAKING SILO'S

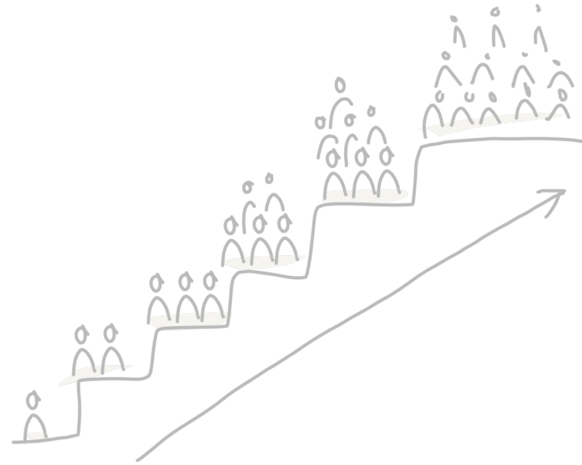

GROW TOGETHER

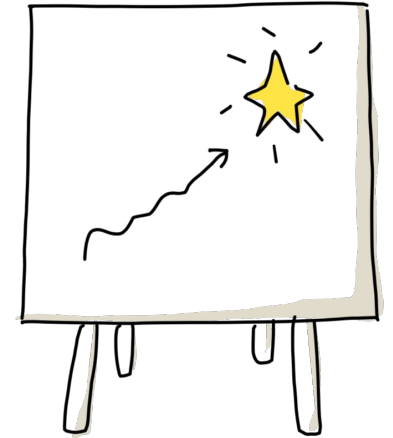

VISUAL THINKING

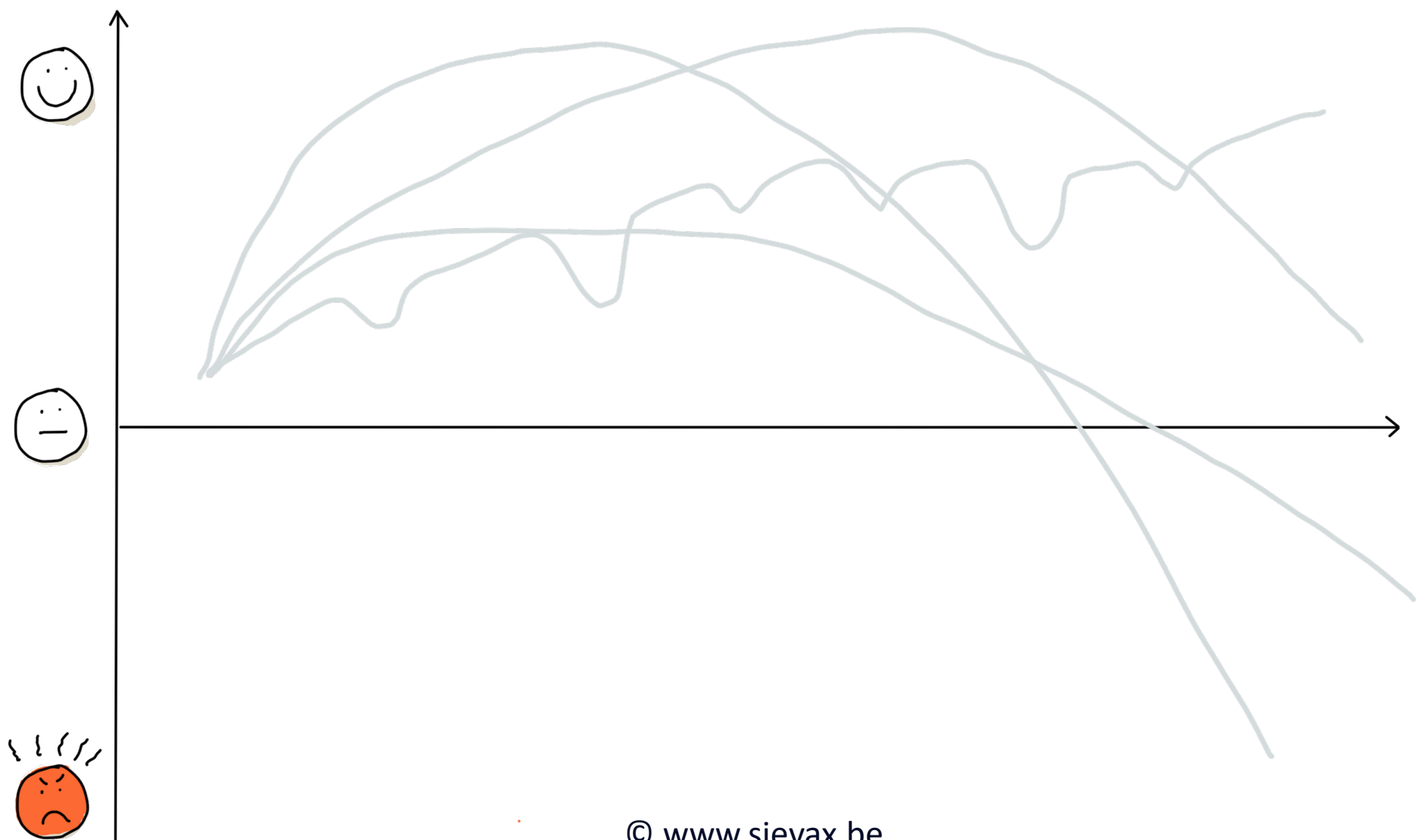

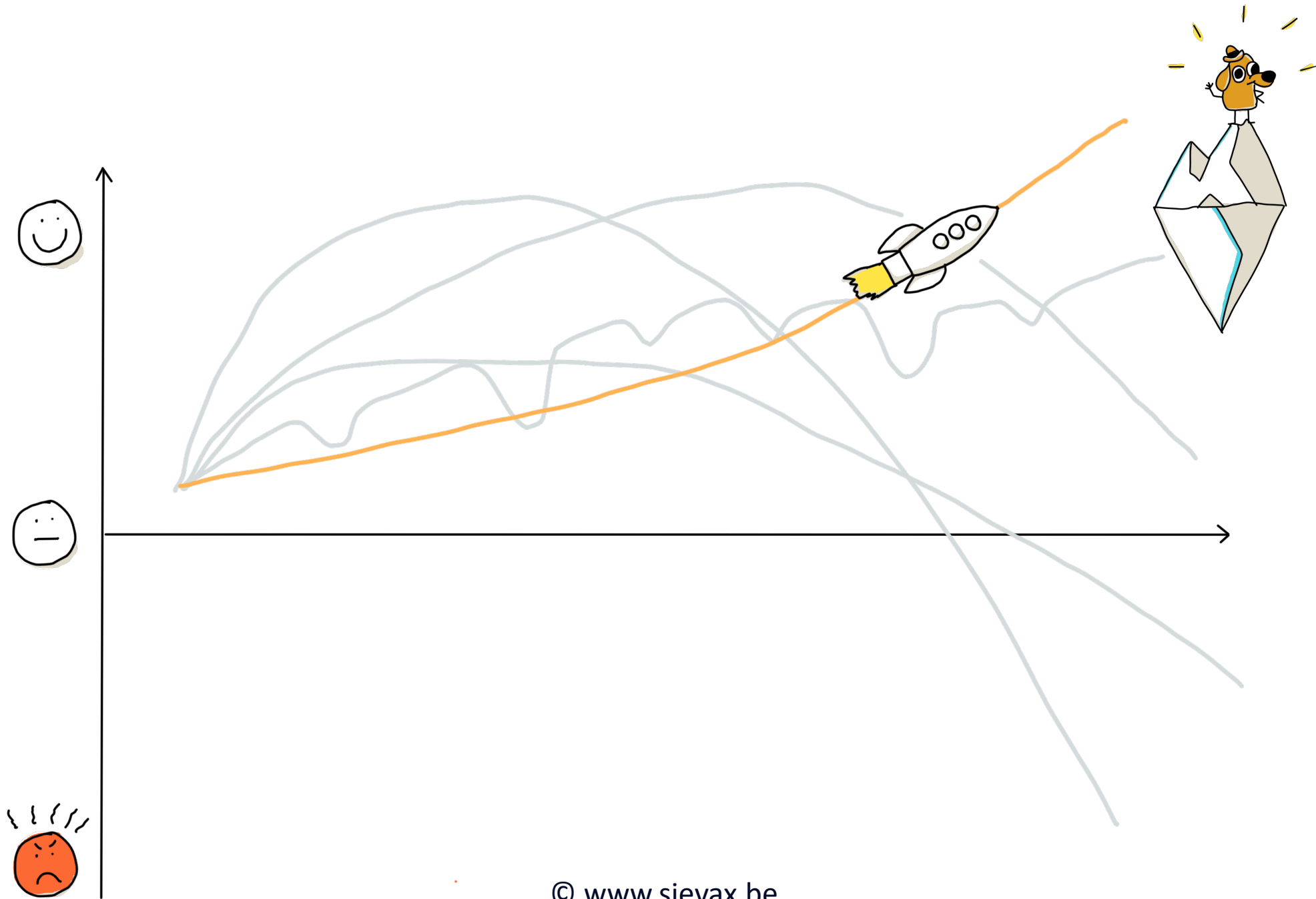

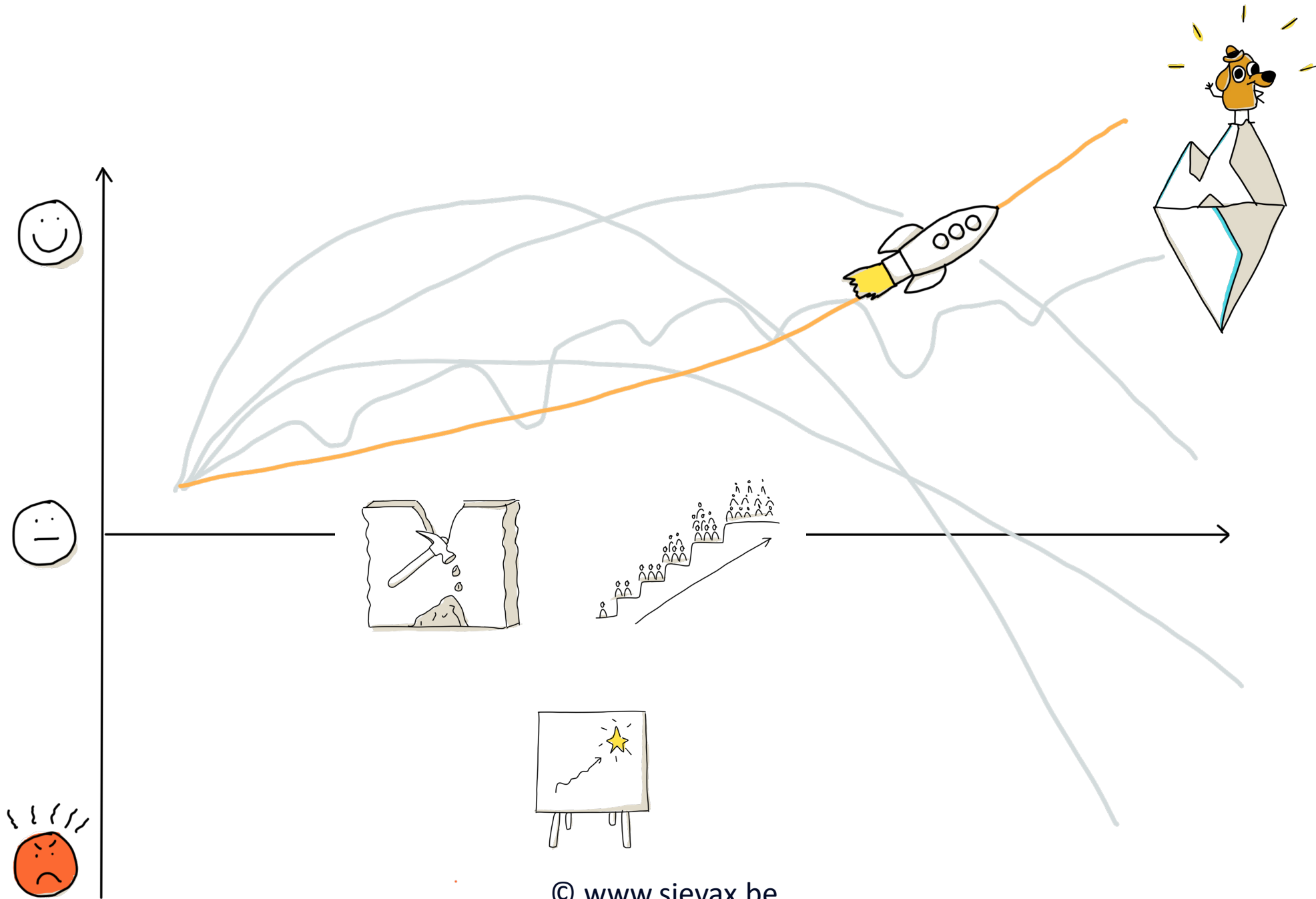

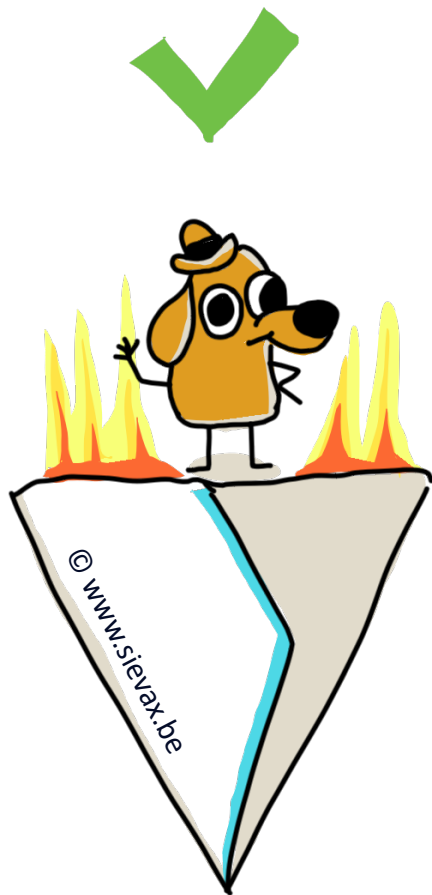



Jan Meskens

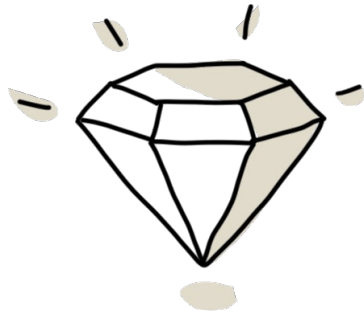

Data and AI Strategy
Consultant

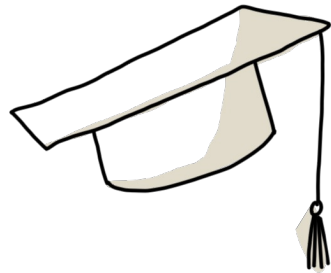

Lecturer of several AI and
Data Strategy Trainings



Founder and Manager
of Sievax

Download Slides:



sievox.be/202411-ai-landscape-talks/

Questions?



[linkedin.com/in/janmeskens](https://www.linkedin.com/in/janmeskens)



medium.com/@meskensjan



www.sievox.be

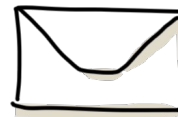

jan@sievox.be